



# i.MX28

## i.MX28 Applications Processors Data Sheet for Consumer Products

### Silicon Version 1.2



#### Package Information

Plastic package  
Case 5284 14 x 14 mm, 0.8 mm Pitch

## 1 Introduction

The i.MX28 is a low-power, high-performance applications processor optimized for the general embedded industrial and consumer markets. The core of the i.MX28 is Freescale's fast, power-efficient implementation of the ARM926EJ-S™ core, with speeds of up to 454 MHz.

The device is suitable for a wide range of applications, including the following:

- Human-machine interface (HMI) panels: industrial, home
- Industrial drive, PLC, I/O control display, factory robotics display, graphical remote controls
- Handheld scanners and printers
- Patient-monitoring, portable medical devices
- Smart energy meters, energy gateways
- Media phones, media gateways

The integrated power management unit (PMU) on the i.MX28 is composed of a triple output DC-DC switching converter and multiple linear regulators. These provide power sequencing for the device and its I/O peripherals such as memories and SD cards, as well as provide battery charging capability for Li-Ion batteries.

#### Ordering Information

See [Table 1 on page 3](#) for ordering information.

#### Contents

1. Introduction	1
1.1. Device Features	2
1.2. Ordering Information & Functional Part Differences	3
1.3. Block Diagram	5
2. Features	5
2.1. Special Signal Considerations	10
3. Electrical Characteristics	11
3.1. i.MX28 Device-Level Conditions	11
3.2. Thermal Characteristics	19
3.3. I/O DC Parameters	19
3.4. I/O AC Timing and Parameters	24
3.5. Module Timing and Electrical Parameters	28
4. Package Information and Contact Assignments	60
4.1. 289-Ball MAPBGA—Case 14 x 14 mm, 0.8 mm Pitch	63
4.2. Ground, Power, Sense, and Reference Contact Assignments	61
4.3. Signal Contact Assignments	62
4.4. i.MX287 Ball Map	65
4.5. i.MX286 Ball Map	66
4.6. i.MX283 Ball Map	67
4.7. i.MX280 Ball Map	68
5. Revision History	69



The i.MX28 processor includes an additional 128-Kbyte on-chip SRAM to make the device ideal for eliminating external RAM in applications with small footprint RTOS.

The i.MX28 supports connections to various types of external memories, such as mobile DDR, DDR2 and LV-DDR2, SLC and MLC NAND Flash.

The i.MX28 can be connected to a variety of external devices such as high-speed USB2.0 OTG, CAN, 10/100 Ethernet, and SD/SDIO/MMC.

## 1.1 Device Features

The following lists the features of the i.MX28:

- ARM926EJ-S CPU running at 454 MHz:
  - 16-Kbyte instruction cache and 32-Kbyte data cache
  - ARM embedded trace macrocell (CoreSight™ ETM9™)
  - Parallel JTAG interface
- 128 KBytes of integrated low-power on-chip SRAM
- 128 KBytes of integrated mask-programmable on-chip ROM
- 1280 bits of on-chip one-time-programmable (OCOTP) ROM
- 16-bit mobile DDR (mDDR) (1.8 V), DDR2 (1.8 V) and LV-DDR2 (1.5 V), up to 205 MHz DDR clock frequency with voltage overdrive
- Support for up to eight NAND flash memory devices with up to 20-bit BCH ECC
- Four synchronous serial ports (SSP) for SDIO/MMC/MS/SPI. Two can be used for SDIO/MMC/MS interfaces (supports SD2.0, eMMC4.4 and MSPro), and all can be used for the SPI interface.
- 10/100-Mbps Ethernet MAC compatible with IEEE Std 802.3™, supporting IEEE Std 1588™-compatible hardware timestamp. Also supports 50-MHz/25-MHz clock output for external Ethernet PHY.
- Two 2.0B protocol-compatible Controller Area Network (CAN) interfaces
- One USB2.0 OTG device/host controller and PHY
- One USB2.0 host controller and PHY
- LCD controller, up to 24-bit RGB (DOTCK) modes and 24-bit system-mode
- Pixel-processing pipeline (PXP) supports full path from color-space conversion, scaling, alpha-blending to rotation without intermediate memory access.
- SPDIF transmitter
- Dual serial audio interface (SAIF) to support full-duplex transmit and receive operations; each SAIF supports three stereo pairs
- Five application Universal Asynchronous Receiver-Transmitters (UARTs), up to 3.25 Mbps with hardware flow control
- One debug UART operating at up to 115 Kb/s using programmed I/O
- Two I<sup>2</sup>C master/slave interfaces, up to 400 kbps
- Four 32-bit timers and a rotary decoder

- Eight Pulse Width Modulators (PWMs)
- Real-time clock (RTC)
- GPIO with interrupt capability
- Power Management Unit (PMU) supports a triple output DC-DC switching converter, multiple linear regulators, battery charger, and detector.
- 16-channel Low-Resolution A/D Converter (LRADC)
- 4/5-wire touchscreen controller
- Up to 8X8 keypad matrix with button-detect circuit
- Single channel High Speed A/D Converter (HSADC), up to 2 Msps data rate
- Security features:
  - Read-only unique ID for Digital Rights Management (DRM) algorithms
  - Secure boot using 128-bit AES hardware decryption
  - SHA-1 and SHA256 hashing hardware
  - High assurance boot (HAB4)
- Offered in 289-pin Ball Grid Array (BGA)

## 1.2 Ordering Information & Functional Part Differences

Table 1 provides the ordering information for the i.MX28.

**Table 1. Ordering Information**

Part Number	Projected Temperature Range (°C)	Package
MCIMX280DVM4B	-20 to +70	14 x 14 mm, 0.8mm pitch, MAPBGA-289
MCIMX280CVM4B	-40 to +85	14 x 14 mm, 0.8mm pitch, MAPBGA-289
MCIMX283DVM4B	-20 to +70	14 x 14 mm, 0.8 mm pitch, MAPBGA-289
MCIMX283CVM4B	-40 to +85	14 x 14 mm, 0.8 mm pitch, MAPBGA-289
MCIMX286DVM4B	-20 to +70	14 x 14 mm, 0.8 mm pitch, MAPBGA-289
MCIMX286CVM4B	-40 to +85	14 x 14 mm, 0.8 mm pitch, MAPBGA-289
MCIMX287CVM4B	-40 to +85	14 x 14 mm, 0.8 mm pitch, MAPBGA-289

Table 2 provides the functional differences between the i.MX280, i.MX283, i.MX286, and the i.MX287.

**Table 2. i.MX28 Functional Differences**

Function	i.MX280	i.MX283	i.MX286	i.MX287
LCD Interface	—	Yes	Yes	Yes
Touch Screen	—	Yes	Yes	Yes
Ethernet	x1	x1	x1	x2
L2 Switch	—	—	—	Yes
CAN	—	—	x2	x2
12-bit ADC	x8	x8	x8	x8

**Table 2. i.MX28 Functional Differences (continued)**

<b>Function</b>	<b>i.MX280</b>	<b>i.MX283</b>	<b>i.MX286</b>	<b>i.MX287</b>
High-speed ADC	x1	x1	x1	x1
USB 2.0	OTG HS with HS PHY x1	OTG HS with HS PHY x1	OTG HS with HS PHY x1	OTG HS with HS PHY x1
	HS Host with HS PHY x1	HS Host with HS PHY x1	HS Host with HS PHY x1	HS Host with HS PHY x1
SDIO	x4	x4	x4	x4
SPI	x4	x4	x4	x4
Application UART	x6	x5	x5	x5
Debug UART	x1	x1	x1	x1
PWM	—	x8	x8	x8
S/PDIF Tx	—	—	Yes	Yes
Security	Yes	Yes	Yes	Yes

## 1.3 Block Diagram

Figure 1 shows the simplified interface block diagram.

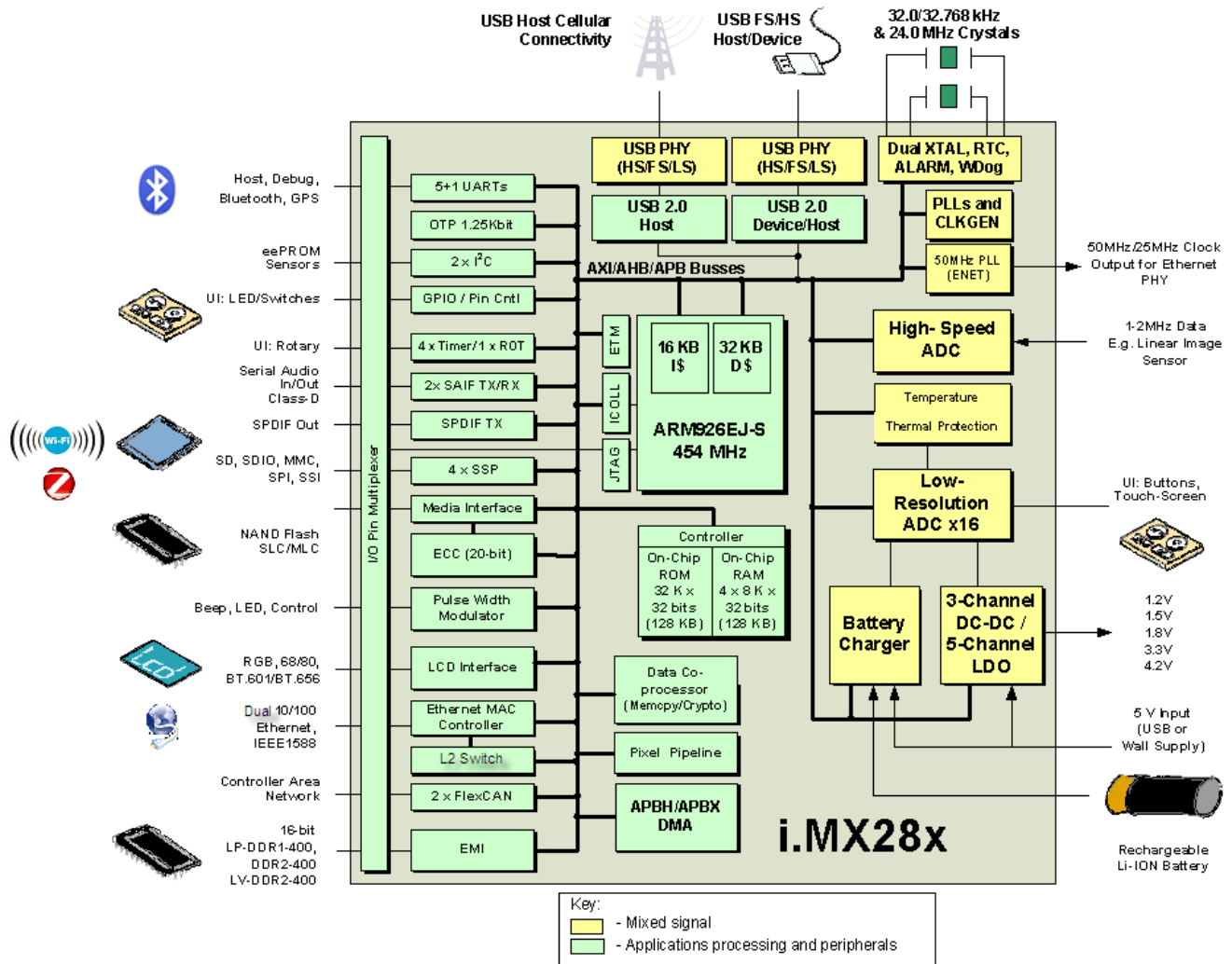


Figure 1. i.MX28 Simplified Interface Block Diagram

## 2 Features

Table 3 shows the device functions.

Table 3. i.MX28 Functions

Function	BGA289
External Memory Interface (EMI) (1.5 V LV-DDR2, 1.8 V DDR2, 1.8 V LP-DDR1)	Yes
General-Purpose Media Interface (GPMI): <ul style="list-style-type: none"> <li>NAND data width</li> <li>Number of external NANDs supported</li> </ul>	8-bit 4 dedicated / 8 with muxing
Pulse Width Modulator (PWM)	5 dedicated / 8 with muxing

**Table 3. i.MX28 Functions (continued)**

Function	BGA289
Application UART (AUART): Interfaces supported	4 dedicated / 5 with muxing
Synchronous Serial Port (SSP): Supported through dedicated pins	3 dedicated / 4 with muxing
I <sup>2</sup> C	1 dedicated / 2 with muxing
SPDIF	1
SAIF	2
FlexCAN	2
LCD interface	24 bits
High-speed ADC	Yes
LRADC (touchscreen, keypad...)	Yes
Ethernet MAC and switch	2 MACs with switch
Universal Serial Bus (USB)	2

Table 4 describes the digital and analog modules of the device.

**Table 4. i.MX28 Digital and Analog Modules**

Block Mnemonic	Block Name	Subsystem	Brief Description
APBHDMA	AHB to APBH Bridge with DMA	System control	The AHB to APBH bridge with DMA includes the AHB-to-APB PIO bridge for memory-mapped I/O to the APB devices, as well a central DMA facility for devices on this bus. The bridge provides a peripheral attachment bus running on the AHB's HCLK. (The 'H' in APBH denotes that the APBH is synchronous to HCLK, as compared to APBX, which runs on the crystal-derived XCLK.) The DMA controller transfers read and write data to and from each peripheral on APBH bridge.
APBXDMA	AHB to APBX Bridge with DMA	System control	The AHB-to-APBX bridge includes the AHB-to-APB PIO bridge for memory-mapped I/O to the APB devices, as well a central DMA facility for devices on this bus. The AHB-to-APBX bridge provides a peripheral attachment bus running on the AHB's XCLK. (The 'X' in APBX denotes that the APBX runs on a crystal-derived clock, as compared to APBH, which is synchronous to HCLK.) The DMA controller transfers read and write data to and from each peripheral on APBX bridge.
ARM9 or ARM926	ARM926EJ-S CPU	ARM®	The ARM926 Platform consists of the ARM926EJ-S™ core and the ETM real-time debug modules. It contains the 16-Kbyte L1 instruction cache, 32-Kbyte L1 data cache, 128-Kbyte ROM and 128-Kbyte RAM.
AUART(5)	Application UART interface	Connectivity peripherals	Each of the UART modules supports the following serial data transmit/receive protocols and configurations: <ul style="list-style-type: none"> <li>• 7- or 8-bit data words, one or two stop bits, programmable parity (even, odd, or none)</li> <li>• Programmable baud rates up to 3.25 MHz. This is a higher maximum baud rate than the 1.875 MHz specified by the TIA/EIA-232-F standard and previous Freescale UART modules. 16-byte FIFO on Tx and 16-byte FIFO on Rx supporting auto-baud detection</li> </ul>

**Table 4. i.MX28 Digital and Analog Modules (continued)**

<b>Block Mnemonic</b>	<b>Block Name</b>	<b>Subsystem</b>	<b>Brief Description</b>
BCH	Bit-correcting ECC accelerator	Connectivity peripherals	The Bose, Ray-Chaudhuri, Hocquenghem (BCH) Encoder and Decoder module is capable of correcting from 2 to 20 single bit errors within a block of data no larger than about 900 bytes (512 bytes is typical) in applications such as protecting data and resources stored on modern NAND flash devices.
BSI	Boundary Scan Interface	Connectivity peripherals	The boundary scan interface is provided to enable board level testing. There are five pins on the device which is used to implement the IEEE Std 1149.1™ boundary scan protocol.
CLKCTRL	Clock control module	Clocks	The clock control module, or CLKCTRL, generates the clock domains for all components in the i.MX28 system. The crystal clock or PLL clock are the two fundamental sources used to produce most of the clock domains. For lower performance and reduced power consumption, the crystal clock is selected. The PLL is selected for higher performance requirements but requires increased power consumption. In most cases, when the PLL is used as the source, a Phase Fractional Divider (PFD) can be programmed to reduce the PLL clock frequency by up to a factor of 2.
DCP	Data co-processor	Security	This module provides support for general encryption and hashing functions typically used for security functions. Because its basic job is moving data from memory to memory, it also incorporates a memory-copy (memcpy) function for both debugging and as a more efficient method of copying data between memory blocks than the DMA-based approach.
DFLPT	Default first-level page table	System control	The DFLPT provides a unique method of implementing the ARM MMU first-level page table (L1PT) using a hardware-based approach.
DIGCTL	Digital control and on-chip RAM	System control	The digital control module includes sections for controlling the SRAM, the performance monitors, high-entropy pseudo-random number seed, free-running microseconds counter, and other chip control functions.
DUART	Debug UART	Connectivity peripherals	The Debug UART performs the following data conversions: <ul style="list-style-type: none"> <li>• Serial-to-parallel conversion on data received from a peripheral device</li> <li>• Parallel-to-serial conversion on data transmitted to the peripheral device</li> </ul>
EMI	External memory interface	Connectivity peripherals	The i.MX28 supports off-chip DRAM storage through the EMI controller, which is connected to the four internal AHB/AXI busses. The EMI supports multiple external memory types, including: <ul style="list-style-type: none"> <li>• 1.8-V Mobile DDR1 (LP-DDR1)</li> <li>• Standard 1.8-V DDR2</li> <li>• Low Voltage 1.5-V DDR2 (LV-DDR2)</li> </ul>
ENET	Ethernet MAC Controller	Connectivity peripherals	Ethernet MAC controller connected to the uDMA (unified DMA). Supports 10/100 Mbps with TCP/UDP/IP Acceleration and IEEE 1588 Functions; also supports RMII or MII connectivity.
FlexCAN(2)	Controller area network module	Connectivity peripherals	The Controller Area Network (CAN) protocol is a message based protocol used for serial data. It was designed specifically for automotive but is also used in industrial control and medical applications. The serial data bus runs at 1 Mbps.
GPMI	General-purpose media interface	Connectivity peripherals	The General-Purpose Media Interface (GPMI) controller is a flexible NAND flash controller with 8-bit data width, up to 50-MBps I/O speed and individual chip select and DMA channels for up to 8 NAND devices. It also provides a interface to 20-bit BCH for ECC.

**Table 4. i.MX28 Digital and Analog Modules (continued)**

<b>Block Mnemonic</b>	<b>Block Name</b>	<b>Subsystem</b>	<b>Brief Description</b>
HSADC	High-speed ADC	Connectivity peripherals	The high-speed ADC block is designed to sample an analog input with 12-bit resolution and a sample rate of up to 2 Msps. The output of the HSADC block can be moved to the external memory through APBH-DMA. A typical user case of the HSADC is to work with the PWM block to drive an external linear image scanner sensor.
I <sup>2</sup> C(2)	I <sup>2</sup> C module	Connectivity peripherals	The I <sup>2</sup> C is a standard two-wire serial interface used to connect the chip with peripherals or host controllers. The I <sup>2</sup> C operates up to 400 kbps in either I <sup>2</sup> C master or I <sup>2</sup> C slave mode. Each I <sup>2</sup> C has a dedicated DMA channel and can also be controlled by CPU in PIO or PIO queue modes. It supports both 7-bit and 10-bit device address in master mode, and has programmable 7-bit address in slave mode.
ICOLL	Interrupt Collector	System control	The ARM9 CPU core has two interrupt input lines, IRQ and FIQ. The interrupt collector (ICOLL) can steer any of 128 interrupt sources to either the FIQ or IRQ line of the ARM9 CPU.
L2 Switch	3-Port L2 Switch	Network Control	Programmable 3-Port Ethernet Switch with QOS
LCDIF	LCD Interface	Multimedia peripherals	The LCDIF provides display data for external LCD panels from simple text-only displays to WVGA, 16/18/24 bpp color TFT panels. The LCDIF supports all of these different interfaces by providing fully programmable functionality and sharing register space, FIFOs, and ALU resources at the same time. The LCDIF supports RGB (DOTCLK) modes as well as system mode including both VSYNC and WSYNC modes.
LRADC	Low resolution ADC module	Connectivity peripherals	The sixteen-channel 12-bit low-resolution ADC (LRADC) block is used for voltage measurement. Channels 0 – 6 measure the voltage on the seven application-dependent LRADC pins. The auxiliary channels can be used for a variety of uses, including a resistor-divider-based wired remote control, external temperature sensing, touch-screen, and other measurement functions.
OCOTP Controller	On-chip OTP controller	Security	The on-chip one-time-programmable (OCOTP) ROM serves the functions of hardware and software capability bits, Freescale operations and unique-ID, the customer-programmable cryptography key, and storage of various ROM configuration bits.
PINCTRL	Pin control and GPIO	System control peripherals	Used for general purpose input/output to external ICs. Each GPIO bank supports 32 bits of I/O.



**Table 4. i.MX28 Digital and Analog Modules (continued)**

<b>Block Mnemonic</b>	<b>Block Name</b>	<b>Subsystem</b>	<b>Brief Description</b>
PMU	Power management Unit (DC-DC)	Power management system	<p>The i.MX28 integrates a comprehensive power supply subsystem, including the following features:</p> <ul style="list-style-type: none"> <li>• One integrated DC-DC converter that supports Li-Ion battery.</li> <li>• Four linear regulators directly power the supply rails from 5-V.</li> <li>• Linear battery charger for Li-Ion cells.</li> <li>• Battery voltage and brownout detection monitoring for VDDD, VDDA, VDDIO, VDD4P2 and 5-V supplies.</li> <li>• Integrated current limiter from 5-V power source.</li> <li>• Reset controller.</li> <li>• System monitors for temperature and speed.</li> <li>• Generates USB-Host 5-V from Li-Ion battery (using PWM).</li> <li>• Support for on-the-fly transitioning between 5-V and battery power.</li> <li>• VDD4P2, a nominal 4.2-V supply, is available when the i.MX28 is connected to a 5-V source and allows the DCDC to run from a 5-V source with a depleted battery.</li> <li>• The 4.2-V regulated output also allows for programmable current limits: <ul style="list-style-type: none"> <li>– Battery Charge current + DCDC input current &lt; the 5-V current limit</li> <li>– DCDC input current (which ultimately provides current to the on-chip and off-chip loads) as the priority and battery charge current is automatically reduced if the 5-V current limit is reached</li> </ul> </li> </ul>
PWM(8)	Pulse width modulation	Connectivity peripherals	<p>There are eight PWM output controllers that can be used in place of GPIO pins. Applications include HSADC driving signals and LED &amp; backlight brightness control. Independent output control of each phase allows 0, 1, or high-impedance to be independently selected for the active and inactive phases. Individual outputs can be run in lock step with guaranteed non-overlapping portions for differential drive applications.</p>
PXP	Pixel Pipeline	Multimedia	<p>The pixel pipeline (PXP) is used to perform alpha blending of graphic or video buffers with graphics data before sending to an LCD display. The PXP also supports image rotation for hand-held devices that require both portrait and landscape image support.</p>
RTC	Real-time clock, alarm, watchdog	Clocks	<p>The real-time clock (RTC) and alarm share a one-second pulse time domain. The watchdog reset and millisecond counter run on a one-millisecond time domain. The RTC, alarm, and persistent bits reside in a special power domain (crystal domain) that remains powered up even when the rest of the chip is in its powered-down state.</p>
SAIF(2)	Serial audio interface	Connectivity peripherals	<p>SAIF provides a half-duplex serial port for communication with a variety of serial devices, including industry-standard codecs and DSPs. It supports a continuous range of sample rates from 8 kHz–192 kHz using a high-resolution fractional divider driven by the PLL. Samples are transferred to/from the FIFO through the APBX DMA interface, a FIFO service interrupt, or software polling.</p>
SPDIF	SPDIF	Connectivity peripherals	<p>The Sony-Philips Digital Interface Format (SPDIF) transmitter module transmits data according to the SPDIF digital audio interface standard (IEC-60958).</p>

**Table 4. i.MX28 Digital and Analog Modules (continued)**

Block Mnemonic	Block Name	Subsystem	Brief Description
SSP(4)	Synchronous serial port	Connectivity peripherals	<p>The synchronous serial port is a flexible interface for inter-IC and removable media control and communication. The SSP supports master operation of SPI, Texas Instruments SSI; 1-bit, 4-bit, and 8-bit SD/SDIO/MMC and 1-bit and 4-bit MS modes.</p> <p>The SPI mode has enhancements to support 1-bit legacy MMC cards. SPI master dual (2-bit) and quad (4-bit) mode reads are also supported. The SSP also supports slave operation for the SPI and SSI modes. The SSP has a dedicated DMA channel in the bridge and can also be controlled directly by the CPU through PIO registers. Each of the four SSP modules is independent of the other and can have separate SSPCLK frequencies.</p>
TIMROT	Timers and Rotary Decoder	Timer peripherals	<p>This module implements four timers and a rotary decoder. The timers and decoder can take their inputs from any of the pins defined for PWM, rotary encoders, or certain divisions from the 32-kHz clock input. Thus, the PWM pins can be inputs or outputs, depending on the application.</p>
USBOTG USBHOST	High-speed USB on-the-go	Connectivity peripherals	<p>The USB module provides high-performance USB On-The-Go (OTG) and host functionality (up to 480 Mbps), compliant with the USB 2.0 specification and the OTG supplement. The module has DMA capabilities for handling data transfer between internal buffers and system memory.</p> <p>When the OTG controller works in device mode, it can only work in FS or HS mode. Two USB2.0 PHYs are also integrated (one for the OTG port, another for the host port.)</p>
USBPHY	Integrated USB PHY	Connectivity peripherals	<p>The integrated USB 2.0 PHY macrocells are capable of connecting to USB host/device systems at the USB low-speed (LS) rate of 1.5 Mbps, full-speed (FS) rate of 12 Mbps or at the USB 2.0 high-speed (HS) rate of 480 Mbps. The integrated PHYs provide a standard UTM interface. The USB_DP and USB_DN pins connect directly to a USB connector.</p>

## 2.1 Special Signal Considerations

Special signal considerations are listed in [Table 5](#). The package contact assignment is found in [Section 4, “Package Information and Contact Assignments.”](#) Signal descriptions are provided in the reference manual.

**Table 5. Signal Considerations**

Signal	Descriptions
PSWITCH	<p>The pin is used for chip power on or recovery. VDDIO can be applied to PSWITCH through a 10 kΩ resistor. This is necessary in order to enter the chip’s firmware recovery. The on-chip circuitry prevents the actual voltage on the pin from exceeding acceptable levels.</p>
VDDXTAL	<p>This pin is an output of i.MX28. Should be coupled to ground with a 0.1 uF capacitor. User should not supply external power to this pin.</p>
BATTERY	<p>This pin should be connected to the battery with minimal resistance. It provides charging current to the battery.</p> <p>See the “Power Supply” section of the reference manual for details.</p>

**Table 5. Signal Considerations (continued)**

Signal	Descriptions
DCDC_BATTERY	This pin is an input of i.MX28 that provides supply to the DCDC converter. It should be connected to the battery with minimal resistance. See the “Power Supply” section of the reference manual for details.
XTALI XTALO	These analog pins are connected to an external 24 MHz crystal circuit. This crystal provides the clock source for on-chip PLLs.
RTC_XTALO RTC_XTALI	These analog pins are connected to an external 32.768/32.0 kHz crystal circuit. This crystal provides clock source to the on-chip real-time counter circuits.
RESETN	This pin resets the chip if it is low. This pin is pulled up to VDDIO33 with an internal 10 kohm resistor. No external pull up resistors are needed.
DEBUG	This pin is used for JTAG interface. DEBUG=0: JTAG interface works for boundary scan. DEBUG=1: JTAG interface works for ARM debugging.
TESTMODE	For Freescale factory use only. Must be externally connected to GND for normal operation.

### 3 Electrical Characteristics

This section provides the device-level and module-level electrical characteristics for the i.MX28.

#### 3.1 i.MX28 Device-Level Conditions

This section provides the device-level electrical characteristics for the IC.

##### 3.1.1 DC Absolute Maximum Ratings

Table 7 provides the DC absolute maximum operating conditions.

#### CAUTION

- Stresses beyond those listed under Table 7 may cause permanent damage to the device.
- Exposure to absolute-maximum-rated conditions for extended periods may affect device reliability.
- Table 6 gives stress ratings only—functional operation of the device is not implied beyond the conditions indicated in Table 8.

**Table 6. DC Absolute Maximum Ratings**

Parameter	Symbol	Min.	Max.	Units
Battery Pin	BATT, V <sub>DD4P2V</sub>	-0.3	4.242	V
5-Volt Source Pin - transient, t<30ms, duty cycle <0.05%	V <sub>DD5V</sub>	-0.3	7.00	V
5 Volt Source Pin - static	V <sub>DD5V</sub>	-0.3	6.00	V
PSWITCH <sup>1</sup>	—	-0.3	BATT/2	V

**Table 6. DC Absolute Maximum Ratings (continued)**

Parameter	Symbol	Min.	Max.	Units
Analog Supply Voltage	V <sub>DDA</sub>	-0.3	2.10	V
Digital Core Supply Voltage	V <sub>DDD</sub>	-0.3	1.575	V
Non-EMI Digital I/O Supply	V <sub>DDIO</sub>	-0.3	3.63	V
EMI Digital I/O Supply	V <sub>DDIO.EMI</sub>	-0.3	3.63	V
DC-DC Converter <sup>2</sup>	DCDC_BATT	-0.3	BATT	V
Input Voltage on Any Digital I/O Pin Relative to Ground	—	-0.3	VDDIO+0.3	V
Input Voltage on USB_DP and USB_DN Pins Relative to Ground <sup>3</sup>	—	-0.3	3.63	V
Analog I/O absolute maximum ratings (exceptions: XTALI, XTALO, RTC_XTALI, RTC_XTALO)	—	-0.3	VDDIO+0.3	V
Storage Temperature	—	-40	125	°C

<sup>1</sup> VDDIO can be applied to PSWITCH through a 10 kΩ resistor. This is necessary in order to enter the chip's firmware recovery mode. (The on-chip circuitry prevents the actual voltage on the pin from exceeding acceptable levels.)

<sup>2</sup> Application should include a Schottky diode between BATT and VDD4P2.

<sup>3</sup> USB\_DN and USB\_DP can tolerate 5V for up to 24 hours. Note that while 5V is applied to USB\_DN or USB\_DP, LRADC readings can be corrupted.

Table 7 shows the electrostatic discharge immunity.

**Table 7. Electrostatic Discharge Immunity**

289-Pin BGA Package	Tested Level
Human Body Model (HBM)	2 kV
Charge Device Model (CDM)	500 V

Note that HBM and CDM pass ESD testing per AEC-Q100.

### 3.1.2 DC Operating Conditions

Table 8 provides the DC recommended operating conditions.

**Table 8. Recommended Power Supply Operating Conditions**

Parameter	Symbol	Min	Typ	Max	Units
Analog Core Supply Voltage	$V_{DDA}$	1.62	—	2.10	V
Digital Core Supply Voltage <i>Specification dependent on frequency.<sup>1, 2</sup></i>	$V_{DDD}$	1.35	—	1.55	V
Digital Supply Voltages: • VDDIO33/VDDIO33_EMI • VDDIO18	$V_{DDIO33}/V_{DDIO33\_EMI}/V_{DDIO18}$	3.0 1.7	— —	3.6 1.9	V
EMI Digital I/O Supply Voltage: • DDR2/mDDR • LVDDR2	$V_{DDIO.EMI}/V_{DDIO\_EMIQ}$	1.7 1.425	1.8 1.5	1.9 1.625	V
Battery / DCDC Input Voltage - BATT, DCDC_BATT	BATT DCDC_BATT	$3.10^3$	—	4.242	V
VDD5V Supply Voltage (5 V current < 100 mA)	—	TBD	5.00	5.25	V
VDD5V Supply Voltage (5V current $\geq$ 100 mA)	—	4.75	5.00	5.25	V
Offstate Current: <sup>4</sup> • 32-kHz RTC off, BATT = 4.2 V • 32-kHz RTC on, BATT = 4.2 V	— —	— —	11 13.5	30 30	$\mu$ A $\mu$ A

<sup>1</sup> For optimum USB jitter performance,  $V_{DDD} = 1.35$  V or greater.

<sup>2</sup>  $V_{DDD}$  supply minimum voltage includes 75 mV guardband.

<sup>3</sup> Tested with only the i.MX28 processor loading the MX28 PMU output rails during start up.

<sup>4</sup> When the real-time clock is enabled, the chip consumes additional current in the OFF state to keep the crystal oscillator and the real-time clock running.

Table 9 provides the DC operating temperature conditions.

**Table 9. Operating Temperature Conditions**

Parameter	Symbol	Min	Typ	Max	Units
Commercial Ambient Operating Temperature Range <sup>1, 2</sup>	$T_A$	-20	—	70	°C
Commercial Junction Temperature Range <sup>1, 2</sup>	$T_J$	-20	—	85	°C
Industrial Ambient Operating Temperature Range <sup>1, 2</sup>	$T_A$	-40	—	85	°C
Industrial Junction Temperature Range <sup>1, 2</sup>	$T_J$	-40	—	105	°C

<sup>1</sup> In most portable systems designs, battery and display specifications limits the operating range to well within these specifications. Most battery manufacturers recommend enabling battery charge only when the ambient temperature is between 0°C and 40°C. To ensure that battery charging does not occur outside the recommended temperature range, the system ambient temperature may be monitored by connecting a thermistor to the LRADC0 or LRADC6 pin on the i.MX28.

- <sup>2</sup> Maximum Ambient Operating Temperature may be limited due to on-chip power dissipation.  $T_{A(MAX)} \leq T_J - (\Theta_{JA} \times P_D)$  where:  
 $T_J$  = Maximum Junction Temperature  
 $\Theta_{JA}$  = Package Thermal Resistance. See [Section 3.2, "Thermal Characteristics."](#)  
 $P_D$  = Total On-chip Power Dissipation = PVDD4P2 + PBatteryCharger + PDCDC + PLinearRegulators + PInternal. Depending on the application, some of these power dissipation terms may not apply.  
 PVDD4P2 = VDD4P2 On-Chip Power Dissipation = (VDD5V - VDD4P2) x IDD4P2  
 PBatteryCharger = Battery Charger On-Chip Power Dissipation = (VDD5V - BATT) x ICHARGE  
 PDCDC = DC-DC Converter On-Chip Power Dissipation = (BATT x DCDC Input Current) x (1 - efficiency)  
 PLinearRegulators = Linear Regulator On-Chip Power Dissipation = (VDD5V - VDDIO) x (IDDIO + IDDA + IDDD + IDD1P5) + (VDDIO - VDDA) x (IDDA + IDDD) + (VDDA - VDDD) x IDDD + (VDDA - VDD1P5) x IDD1P5  
 PInternal = Internal Digital On-Chip Power Dissipation = ~VDDD x IDDD

[Table 10](#) provides the recommended analog operating conditions.

**Table 10. Recommended Analog Operating Conditions**

Parameter	Min	Typ	Max	Units
Low Resolution ADC Input Impedance (CH0 - CH5)	>1	—	—	MΩ

[Table 11](#) shows the PSWITCH input characteristics. See the reference schematics for the recommended PSWITCH button circuitry.

**Table 11. PSWITCH Input Characteristics**

Parameter	HW_PWR_STS_PSWITCH	Min	Max	Units
PSWITCH LOW LEVEL	0x00	0.00	0.30	V
PSWITCH MID LEVEL & STARTUP <sup>1</sup>	0x01	0.65	1.50	V
PSWITCH HIGH LEVEL <sup>2</sup>	0x11	(1.1 * VDDXTAL) + 0.58	2.45	V

<sup>1</sup> A MID LEVEL PSWITCH state can be generated by connecting the VDDXTAL output of the SOC to PSWITCH through a switch.

<sup>2</sup> PSWITCH acts like a high impedance input (>300 kΩ) when the voltage applied to it is less than 1.5V. However, above 1.5V it becomes lower impedance. To simplify design, it is recommended that a 10 kΩ resistor to VDDIO be applied to PSWITCH to set the HIGH LEVEL state (the PSWITCH input can tolerate voltages greater than 2.45 V as long as there is a 10 kΩ resistor in series to limit the current).

[Table 12](#) shows the power consumption.

**Table 12. Power Consumption**

Parameter	Min	Typ	Max	Units
Power Consumption: Conditions - TBD	—	TBD	—	mW

Table 13 illustrates the power supply characteristics.

**Table 13. Power Supply Characteristics**

Parameter	Min	Typ	Max	Units
<b>Linear Regulators</b>				
Output Voltage Accuracy ( $V_{DDIO}$ , $V_{DDA}$ , $V_{DDM}$ , $V_{DDD}$ ) <sup>1</sup>	-3	—	+3	%
$V_{DDIO}$ Maximum Output Current ( $V_{DDIO} = 3.30$ V, $V_{DD5V} = 4.75$ V) <sup>2, 3</sup>	270	—	—	mA
$V_{DDIO}$ Maximum Output Current ( $V_{DDIO} = 3.30$ V, $V_{DD5V} = 4.40$ V) <sup>2, 3</sup>	200	—	—	mA
$V_{DDM}$ Maximum Output Current ( $V_{DDM} = 1.5$ V) <sup>2</sup>	160	—	—	mA
$V_{DDA}$ Maximum Output Current ( $V_{DDA} = 1.8$ V) <sup>2, 3</sup>	225	—	—	mA
$V_{DDD}$ Maximum Output Current ( $V_{DDD} = 1.2$ V) <sup>2, 3</sup>	200	—	—	mA
<b>DCDC Converters</b>				
Output Voltage Accuracy (DCDC_VDDIO, DCDC_VDDA, DCDC_VDDD) <sup>1</sup>	-3	—	+3	%
DCDC_VDDD Maximum Output Current ( $V_{DDD} = 1.55$ V) <sup>4, 5</sup>	250	—	—	mA
DCDC_VDDA Maximum Output Current ( $V_{DDA} = 1.8$ V) <sup>4, 5</sup>	200	—	—	mA
DCDC_VDDIO Maximum Output Current ( $V_{DDIO} = 3.15$ V, $3.3$ V < BATT < 4.242 V) <sup>4, 5, 6</sup>	250	—	—	mA
<b>VDD4P2 Regulated Output</b>				
VDD4P2 Output Voltage Accuracy (TARGET=4.2V) <sup>1</sup>	-3	—	+3	%
VDD4P2 Output Current Limit Accuracy ( $V_{DD5V} = 4.75$ V, ILIMIT=480 mA) <sup>7</sup>	TBD	480	TBD	mA
VDD4P2 Output Current Limit Accuracy ( $V_{DD5V}=4.75$ V, ILIMIT=100 mA) <sup>7</sup>	TBD	100	TBD	mA
<b>Battery Charger</b>				
Final Charge Voltage Accuracy (TARGET=4.2 V)	-2	—	+1	%

<sup>1</sup> No load.

<sup>2</sup> Maximum output current measured when output voltage droops 100 mV from the programmed target voltage with no load present.

<sup>3</sup> Because the internal linear regulators are cascaded, it is not possible to simultaneously operate the  $V_{DDIO}$ ,  $V_{DDA}$ ,  $V_{DDM}$ , and  $V_{DDD}$  linear regulators at the maximum specified load current. For example, the  $V_{DDIO}$  linear regulator provides current to both the  $V_{DDIO}$  3.3 V supply rail as well as the  $V_{DDM}$  and  $V_{DDA}$  linear regulator inputs. Likewise, the  $V_{DDA}$  linear regulator provides current to both the 1.8 V supply rail as well as the  $V_{DDD}$  linear regulator input. The application designer should ensure the following two conditions are met:

$$(V_{DDIO} \text{ Load Current} + V_{DDM} \text{ Load Current} + V_{DDA} \text{ Load Current}) < V_{DDIO} \text{ Maximum Output Current}$$

$$(V_{DDA} \text{ Load Current} + V_{DDD} \text{ Load Current}) < V_{DDA} \text{ Maximum Output Current}$$

<sup>4</sup> DCDC Double FETs Enabled, Inductor Value = 15  $\mu$ H.

<sup>5</sup> The DCDC Converter is a triple output buck converter. The maximum output current capability of each output of the converter is dependent on the loads on the other two outputs. For a given output, it may be possible to achieve a maximum output current higher than that specified by ensuring the load on the other outputs is well below the maximum.

<sup>6</sup> Assumes simultaneous load of  $I_{DDD} = 250$  mA @ 1.55 V and  $I_{DDA} = 200$  mA @ 1.8 V.

<sup>7</sup> Untuned.

### 3.1.2.1 Recommended Operating Conditions for Specific Clock Targets

Table 14 through Table 18 provide the recommended operating conditions for specific clock targets.

**Table 14. System Clocks**

Name	Min. Freq. (MHz)	Max. Freq. (MHz)	Description
clk_gpmi	—	TBD	General purpose memory interface clock domain
clk_ssp	—	TBD	SSP interface clock domain

**Table 15. Recommended Operating States—289-Pin BGA Package**

VDDD (V)	VDDD Brown-out (V)	HW_DIGCTRL ARMCACHE <sup>E1</sup>	CPUCLK / clk_p Frequency (MHz)	HW_CLKCTRL CPU_DIV_CPU	HW_CLKCTRL FRAC_CPUFRC / PFD	AHBCLK / clk_h Frequency (MHz)	HW_CLKCTRL HBUS_DIV	EMICKL / clk_emi Frequency (MHz)	HW_CLKCTRL EMI_DIV_EMI	HW_CLKCTRL FRAC_EMIFRAC	Supported DRAM
TBD	TBD	00	64	5	27	64	1	130.91	2	33	DDR2 mDDR
1.350	1.250	00	261.81	1	33	130.91	2	130.91	2	33	DDR2 mDDR
1.350	1.250	00	360	1	24	120.00	3	130.91	2	33	DDR2 mDDR
1.450	1.350	00	392.72	1	22	130.91	3	160.00	2	27	DDR2 mDDR
1.550	1.450	00	454.73	1	19	151.57	3	205.71	2	21	DDR2 mDDR

<sup>1</sup> All timing control bit fields in HW\_DIGCTRL\_ARMCACHE should be set to the same value.

**Table 16. Recommended Operating Conditions—CPU Clock (clk\_p)**

Minimum VDDD (V)	Minimum VDDD <sub>Brown-out</sub> (V)	HW_DIGCTRL ARMCACHE <sup>1</sup>	HW_CLKCTRL FRAC_CPUFRC / PFD	CPUCLK / clk_p Frequency max (MHz)
TBD	TBD	00	27 - 35	TBD
1.350	1.250	00	18 - 35	360
1.450	1.350	00	18 - 35	392.72
1.550	1.450	00	18 - 35	454.73

<sup>1</sup> All timing control bit fields in HW\_DIGCTRL\_ARMCACHE should be set to the same value.



**Table 17. Recommended Operating Conditions—AHB Clock (clk\_h)**

Minimum VDDD (V)	Minimum VDDD <sub>Brown-out</sub> (V)	HW_DIGCTRL ARMCACHE <sup>1</sup>	HW_CLKCTRL FRAC_CPUFRC / PFD	AHBCLK / clk_h Frequency max (MHz)
TBD	TBD	00	27 - 35	TBD
1.350	1.250	00	18 - 35	160
1.450	1.350	00	18 - 35	196
1.550	1.45	00	18 - 35	206

<sup>1</sup> All timing control bit fields in HW\_DIGCTRL\_ARMCACHE should be set to the same value.

**Table 18. Frequency vs. Voltage for EMICKL—289-Pin BGA Package**

Minimum VDDD (V)	Minimum VDDD <sub>Brownout</sub> (V)	EMICKL Fmax (MHz)	
		DDR2	mDDR
1.550	1.450	205.71	205.71
1.450	1.350	196.36	196.36
1.350	1.250	196.36	196.36

### 3.1.3 Fusebox Supply Current Parameters

Table 19 lists the fusebox supply current parameters.

**Table 19. Fusebox Supply Current Parameters**

Parameter	Symbol	Min	Typ	Max	Units
eFuse Program Current <sup>1</sup> Current to program one eFuse bit efuse_vddq=2.5V	I <sub>program</sub>	21.39	25.05	33.54	mA
eFuse Read Current <sup>2</sup> Current to read an 8-bit eFuse word vdd_fusebox = 3.3 V	I <sub>read</sub>	—	—	4.07	mA

<sup>1</sup> The current I<sub>program</sub> is during program time.

<sup>2</sup> The current I<sub>read</sub> is present for approximately 10 ns of the read access to the 8-bit word.

### 3.1.4 Interface Frequency Limits

Table 20 provides information for interface frequency limits.

**Table 20. Interface Frequency Limits**

Parameter	Min.	Typ.	Max.	Units
JTAG: TCK Frequency of Operation	—	—	10	MHz
OSC24M_XTAL Oscillator	—	24.000	—	MHz
OSC32K_XTAL Oscillator	—	32.768/32.0	—	KHz

### 3.1.5 Power Modes

Table 21 describes the core, clock, and module settings for the different power modes of the processor.

**Table 21. Power Mode Settings**

Core/Clock/Module	Deep-Sleep	Standby	Run
ARM Core	Off	Off	On
USB0 PLL (System PLL)	Off	Off	On
OSC24M	Off	On	On
OSC32K	On	On	On
DCDC	Off	On	On
RTC	On	On	On
Other Modules	Off	On/Off	On/Off

### 3.1.6 Supply Power-Up/Power-Down Requirements

There is no special power-up sequence. After applying 5 V or battery in any order, the rest of the power supplies are internally generated and automatically come up in a safe way.

There is no special power-down sequence. 5 V or the battery can be removed at any time.

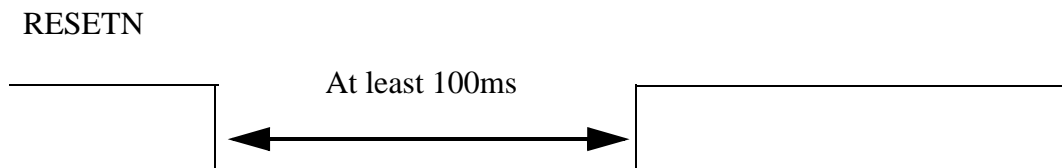
### 3.1.7 Reset Timing

Because the i.MX28 is a PMU and an SoC, power-on reset is generated internally and there is no timing requirement on external pins.

The i.MX28 can be reset by asserting the external pin RESETN for at least 100 mS and later deasserting RESETN.

If the reset occurs while the device is only powered by the battery, then the reset kills all of the power supplies and the system reboots on the assertion of PSWITCH. If auto-restart is set up ahead of time, the system reboots immediately.

If the chip is powered by 5 V, then the reset serves to reset the digital sections of the chip. If the DCDC is operating at the time of the reset, then power switches back to the default linear regulators powered by 5 V.



**Figure 2. RESETN Timing**

## 3.2 Thermal Characteristics

The thermal resistance characteristics for the device are given in [Table 22](#). These values are measured under the following conditions:

- Two layer Substrate
- Substrate solder mask thickness: 0.025 mm
- Substrate metal thicknesses: 0.016 mm
- Substrate core thickness: 0.160 mm
- Core via I.D: 0.068 mm, Core via plating 0.016 mm
- Flag: trace style with ground balls under the die connected to the flag
- Die Attach: 0.033 mm non-conductive die attach,  $k = 0.3 \text{ W/m K}$
- Mold Compound: generic mold compound,  $k = 0.9 \text{ W/m K}$

**Table 22. Thermal Resistance Data**

Rating			Value	Unit
Junction to ambient <sup>1</sup> natural convection	Single layer board (1s)	$R_{\theta JA}$	62	°C/W
Junction to ambient <sup>1</sup> natural convection	Four layer board (2s2p)	$R_{\theta JA}$	36	°C/W
Junction to ambient <sup>1</sup> (@200 ft/min)	Single layer board (1s)	$R_{\theta JMA}$	53	°C/W
Junction to ambient <sup>1</sup> (@200 ft/min)	Four layer board (2s2p)	$R_{\theta JMA}$	33	°C/W
Junction to boards <sup>2</sup>		$R_{\theta JB}$	24	°C/W
Junction to case (top) <sup>3</sup>		$R_{\theta JCTop}$	15	°C/W
Junction to package top <sup>4</sup>	Natural Convection	$\Psi_{JT}$	3	°C/W

<sup>1</sup> Junction-to-Ambient Thermal Resistance determined per JEDEC JESD51-2 and JESD51-6. Thermal test board meets JEDEC specification for this package.

<sup>2</sup> Junction-to-Board thermal resistance determined per JEDEC JESD51-8. Thermal test board meets JEDEC specification for the specified package.

<sup>3</sup> Junction-to-Case at the top of the package determined using MIL-STD 883 Method 1012.1. The cold plate temperature is used for the case temperature. Reported value includes the thermal resistance of the interface layer.

<sup>4</sup> Thermal characterization parameter indicating the temperature difference between the package top and the junction temperature per JEDEC JESD51-2. When Greek letters are not available, the thermal characterization parameter is written as Psi-JT.

## 3.3 I/O DC Parameters

This section includes the DC parameters of the following I/O types:

- DDR I/O: Mobile DDR (LPDDR1), standard 1.8 V DDR2, and low-voltage 1.5 V DDR2 (LVDDR2)
- General purpose I/O (GPIO)

### 3.3.1 DDR I/O DC Parameters

Table 23 shows the EMI digital pin DC characteristics.

#### NOTE

The current values and the I-V curves of the I/O DC characteristics are estimated based on an overly conservative device model. They are updated upon the measurement results of the first silicon.

**Table 23. EMI Digital Pin DC Characteristics**

Parameter	Symbol	Min.	Max.	Units
Input voltage high (dc)	VIH	VREF + 0.125	VDDIO_EMI + 0.3	V
Input voltage low (dc)	VIL	0.3	VREF – 0.125	V
Output voltage high (dc)	VOH	0.8 * VDDIO_EMI	—	V
Output voltage low (dc)	VOL	-	0.2 * VDDIO_EMI	V
Output source current (dc) LVDDR2 Mode	IOH <sup>1</sup> —Low	TBD	TBD	mA
	IOH—Medium	TBD	TBD	mA
	IOH—High	TBD	TBD	mA
Output sink current (dc) LVDDR2 Mode	IOL <sup>2</sup> —Low	TBD	TBD	mA
	IOL—Medium	TBD	TBD	mA
	IOL—High	TBD	TBD	mA
Output source current (dc) mDDR, DDR2 Mode	IOH—Low	TBD	TBD	mA
	IOH—Medium	TBD	TBD	mA
	IOH—High	TBD	TBD	mA
Output sink current (dc) mDDR, DDR2 Mode	IOL—Low	TBD	TBD	mA
	IOL—Medium	TBD	TBD	mA
	IOL—High	TBD	TBD	mA

<sup>1</sup> IOH is the output current at which the VOH specification is met.

<sup>2</sup> IOL is the output current at which the VOL specification is met.

Table 24 shows the ON impedance of EMI drivers for different drive strengths.

**Table 24. ON Impedance of EMI Drivers for Different Drive Strengths**

Mode	Drive	Min. ( $\Omega$ )	Typ. ( $\Omega$ )	Max. ( $\Omega$ )
1.5 LVDDR2	Low	TBD	TBD	TBD
	Medium	TBD	TBD	TBD
	High	TBD	TBD	TBD

**Table 24. ON Impedance of EMI Drivers for Different Drive Strengths (continued)**

Mode	Drive	Min. ( $\Omega$ )	Typ. ( $\Omega$ )	Max. ( $\Omega$ )
1.8 DDR2/mDDR	Low	TBD	TBD	TBD
	Medium	TBD	TBD	TBD
	High	TBD	TBD	TBD

Table 25 shows the external devices supported by the EMI.

**Table 25. External Devices Supported by the EMI**

DRAM Device	Max Load <sup>1, 2</sup>	Pad Voltage
DDR2	15 pF	1.8 V
mDDR	15 pF	1.8 V
LVDDR2	15 pF	1.5 V

<sup>1</sup> Max load includes capacitive load due to PCB traces, pad capacitance and driver self-loading.

<sup>2</sup> Setting is for worst case. Freescale's EMI interface uses less powerful drivers than those typically used in mDDR devices. A possible transmission-line effect on the PC board must be suppressed by minimizing the trace length combined with Freescale's slower edge-rate drivers. The i.MX28 provides up to 16 mA programmable drive strength. However, the 16-mA mode is an experimental mode. With the 16-mA mode, the EMI function may be impaired by Simultaneous Switching Output (SSO) noise. In general, the stronger the driver mode, the noisier the on-chip power supply. Freescale recommends not using a stronger driver mode than is required. Because on-chip power and ground noise is proportional to the inductance of its return path, users should make their best effort to reduce inductance between the EMI power and ground balls and the PC board power and ground planes.

### 3.3.2 GPIO I/O DC Parameters

Max load includes capacitive load due to PCB traces, pad capacitance and driver self-loading. For the internal pull up setting of each pad, see the "Pin Control and GPIO" section of the reference manual.

Table 26 shows the digital pin DC characteristics for GPIO in 3.3-V mode. Measurements are valid for eight pins loaded using the 4mA driver, four pins loaded using the 8mA driver, and two pins loaded using either the 12mA or 16mA driver.

**Table 26. Digital Pin DC Characteristics for GPIO in 3.3-V Mode**

Parameter	Symbol	Min	Max	Units
Input voltage high (dc)	V <sub>IH</sub>	2	VDDIO	V
Input voltage low (dc)	V <sub>IL</sub>	—	0.8	V
Output voltage high (dc)	V <sub>OH</sub>	0.8 × VDDIO	—	V
Output voltage low (dc)	V <sub>OL</sub>	—	0.4	V
Output source current <sup>1</sup> (dc) <i>gpio</i>	IOH – Low	-5.0	—	mA
	IOH – Medium	-9.5	—	mA
	IOH – High	-11.4	—	mA

**Table 26. Digital Pin DC Characteristics for GPIO in 3.3-V Mode (continued)**

Parameter	Symbol	Min	Max	Units
Output sink current <sup>1</sup> (dc) <i>gpio</i>	IOL – Low	3.8	—	mA
	IOL – Medium	7.7	—	mA
	IOL – High	9.0	—	mA
Output source current <sup>1</sup> (dc) <i>gpio_clk</i>	IOH – Low	-9.2	—	mA
	IOH – High	-15.2	—	mA
Output sink current <sup>1</sup> (dc) <i>gpio_clk</i>	IOL – Low	7.6	—	mA
	IOL – High	12.0	—	mA
10-K pull-up resistance <sup>2</sup>	Rpu10k	8	12	K $\Omega$
47-K pull-up resistance <sup>2</sup>	Rpu47k	39	56	K $\Omega$

<sup>1</sup> The conditions of the current measurements for all different drives are as follows:

IOL: at 0.4 V

IOH: at VDDIO \* 0.8 V

Maximum corner for 3.3 V mode: 3.6 V, -40°C, fast process.

Minimum corner for 3.3 V mode: 3.0 V, 105°C, slow process

8 *gpio* pins (LCD\_D0-D7) and 2 *gpio\_clk* pins (LCD\_DOTCLK and LCD\_WR\_RWN) simultaneously loaded.

<sup>2</sup> See the i.MX28 reference manual for detailed pull-up configuration of each I/O.

Table 27 shows the digital pin DC characteristics for GPIO in 1.8 V mode.

**Table 27. Digital Pin DC Characteristics for GPIO in 1.8 V Mode**

	Symbol	Min	Max	Units
Input voltage high (DC)	VIH	$0.7 \times VDDIO18$	VDDIO18	V
Input voltage low (DC)	VIL	—	$0.3 \times VDDIO18$	V
Output voltage high (DC)	VOH	$0.8 * VDDIO18$	—	V
Output voltage low (DC)	VOL	—	$0.2 \times VDDIO18$	V
Output source current <sup>1</sup> (DC) <i>gpio</i>	IOH – low	-2.2	—	mA
	IOH – medium	-3.5	—	mA
	IOH – high	-4.0	—	mA
Output sink current <sup>1</sup> (DC) <i>gpio</i>	IOL – low	3.3	—	mA
	IOL – medium	7.0	—	mA
	IOL – high	7.5	—	mA
Output source current <sup>1</sup> (DC) <i>gpio_clk</i>	IOH – low	-4.2	—	mA
	IOH – high	-6.0	—	mA
Output sink current <sup>1</sup> (DC) <i>gpio_clk</i>	IOL – low	6.8	—	mA
	IOL – high	11.5	—	mA
10-K pull-up resistance <sup>2</sup>	Rpu10k	8	12	K $\Omega$
47-K pull-up resistance <sup>2</sup>	Rpu47k	39	56	K $\Omega$

<sup>1</sup> The condition of the current measurements for all different drives are as follows:

Maximum corner for 1.8 V mode: 1.9 V, -40°C, Fast process.

Minimum corner for 1.8 V mode: 1.7 V, 105°C, Slow process.

1 *gpio* pin (GPMI\_D0) and 1 *gpio\_clk* pin (GPMI\_WRN) simultaneously loaded.

<sup>2</sup> See the i.MX28 reference manual for detailed pull-up configuration of each I/O.

### 3.4 I/O AC Timing and Parameters

Figure 3 and Figure 4 show the Driver Used for AC Simulation Testpoint and the Output Pad Transition Waveform.

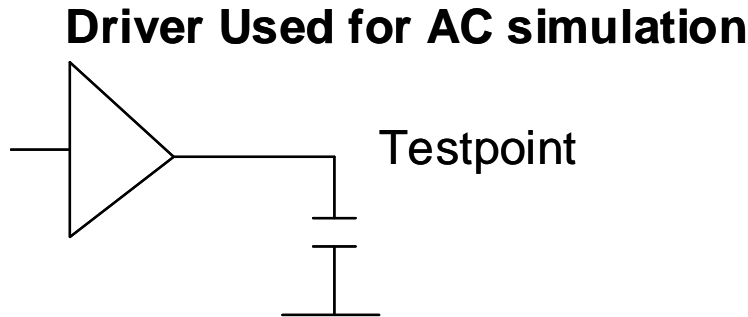


Figure 3. Driver Used for AC Simulation Testpoint

### Output Pad Transition Waveform



Figure 4. Output Pad Transition Waveform

Table 28 shows the base GPIO AC timing and parameters.

Table 28. Base GPIO

Parameters	Symbol	Test Voltage	Test Capacitance	Min Rise/Fall		MaxRise/Fall		Units	Notes
Duty cycle	Fduty	—	—	—	—	—	—	%	—
Output pad transition times (maximum drive)	tpr	1.7~1.9V	10pF	0.82	0.91	1.93	1.97	ns	—
		1.7~1.9V	20pF	1.18	1.22	2.69	2.71		—
		1.7~1.9V	50pF	2.11	2.03	4.62	4.44		—
		3.0~3.6V	10pF	1.04	1.08	2.46	2.18		—
		3.0~3.6V	20pF	1.42	1.5	3.29	3		—
		3.0~3.6V	50pF	2.46	2.61	5.34	5.12		—



**Table 28. Base GPIO (continued)**

Parameters	Symbol	Test Voltage	Test Capacitance	Min Rise/Fall		MaxRise/Fall		Units	Notes
Output pad transition times (medium drive)	tpr	1.7~1.9V	10pF	1.02	1.08	2.34	2.38	ns	—
		1.7~1.9V	20pF	1.51	1.5	3.34	3.28		—
		1.7~1.9V	50pF	2.91	2.62	6.24	5.67		—
		3.0~3.6V	10pF	1.26	1.29	2.9	2.6		—
		3.0~3.6V	20pF	1.8	1.88	4	3.67		—
		3.0~3.6V	50pF	3.3	3.46	6.91	6.64		—
Output pad transition times (low drive)	tpr	1.7~1.9V	10pF	1.62	1.68	3.65	3.68	ns	—
		1.7~1.9V	20pF	2.55	2.45	5.59	5.37		—
		1.7~1.9V	50pF	5.42	4.62	11.46	10.01		—
		3.0~3.6V	10pF	1.95	2.12	4.43	4.25		—
		3.0~3.6V	20pF	2.96	3.21	6.36	6.25		—
		3.0~3.6V	50pF	5.89	6.39	12.02	12.18		—
Output pad slew rate (maximum drive)	tps	1.7~1.9V	10pF	1.39	1.25	0.53	0.52	V/ns	—
		1.7~1.9V	20pF	0.97	0.93	0.38	0.38		—
		1.7~1.9V	50pF	0.54	0.56	0.22	0.23		—
		3.0~3.6V	10pF	2.08	2.00	0.73	0.83		—
		3.0~3.6V	20pF	1.52	1.44	0.55	0.60		—
		3.0~3.6V	50pF	0.88	0.83	0.34	0.35		—
Output pad slew rate (medium drive)	tps	1.7~1.9V	10pF	1.12	1.06	0.44	0.43	V/ns	—
		1.7~1.9V	20pF	0.75	0.76	0.31	0.31		—
		1.7~1.9V	50pF	0.39	0.44	0.16	0.18		—
		3.0~3.6V	10pF	1.71	1.67	0.62	0.69		—
		3.0~3.6V	20pF	1.20	1.15	0.45	0.49		—
		3.0~3.6V	50pF	0.65	0.62	0.26	0.27		—
Output pad slew rate (low drive)	tps	1.7~1.9V	10pF	1.17	1.13	0.47	0.46	V/ns	—
		1.7~1.9V	20pF	0.75	0.78	0.30	0.32		—
		1.7~1.9V	50pF	0.35	0.41	0.15	0.17		—
		3.0~3.6V	10pF	1.11	1.02	0.41	0.42		—
		3.0~3.6V	20pF	0.73	0.67	0.28	0.29		—
		3.0~3.6V	50pF	0.37	0.34	0.15	0.15		—
Input pad average hysteresis	tih	1.7 V–1.9 V	—	100		75		mV	—
		3.0 V–3.6 V	—	100		50			—

Table 29 shows the F-type GPIO AC timing and parameters.

**Table 29. F-type GPIO**

Parameters	Symbol	Test Voltage	Test Capacitance	Min Rise/Fall		Max Rise/Fall		Units	Notes
Duty cycle	Fduty	—	—	—		—		%	—
Output pad transition times (maximum drive)	tpr	1.7~1.9V	10pF	0.58	0.61	1.29	1.33	ns	—
		1.7~1.9V	20pF	0.89	0.88	1.94	1.88		—
		1.7~1.9V	50pF	1.83	1.59	3.88	3.39		—
		3.0~3.6V	10pF	0.71	0.68	1.47	1.34		—
		3.0~3.6V	20pF	1.02	1.04	2.11	1.99		—
		3.0~3.6V	50pF	1.98	2.09	3.97	3.96		—
Output pad transition times (medium drive)	tpr	1.7~1.9V	10pF	0.76	0.76	1.68	1.61	ns	—
		1.7~1.9V	20pF	1.23	1.13	2.63	2.38		—
		1.7~1.9V	50pF	2.66	2.18	5.61	4.6		—
		3.0~3.6V	10pF	0.9	0.88	1.84	1.7		—
		3.0~3.6V	20pF	1.36	1.4	2.76	2.67		—
		3.0~3.6V	50pF	2.85	3.02	5.59	5.67		—
Output pad transition times (low drive)	tpr	1.7~1.9V	10pF	1.32	1.26	2.88	2.72	ns	—
		1.7~1.9V	20pF	2.27	1.98	4.84	4.23		—
		1.7~1.9V	50pF	5.23	4.13	10.95	8.8		—
		3.0~3.6V	10pF	1.46	1.55	3.05	3		—
		3.0~3.6V	20pF	2.46	2.62	4.92	5.02		—
		3.0~3.6V	50pF	5.56	5.96	10.78	11.22		—
Output pad slew rate (maximum drive)	tps	1.7~1.9V	10pF	1.97	1.87	0.79	0.77	ns	—
		1.7~1.9V	20pF	1.28	1.30	0.53	0.54		—
		1.7~1.9V	50pF	0.62	0.72	0.26	0.30		—
		3.0~3.6V	10pF	3.04	3.18	1.22	1.34		—
		3.0~3.6V	20pF	2.12	2.08	0.85	0.90		—
		3.0~3.6V	50pF	1.09	1.03	0.45	0.45		—
Output pad slew rate (medium drive)	tps	1.7~1.9V	10pF	1.50	1.50	0.61	0.63	ns	—
		1.7~1.9V	20pF	0.93	1.01	0.39	0.43		—
		1.7~1.9V	50pF	0.43	0.52	0.18	0.22		—
		3.0~3.6V	10pF	2.40	2.45	0.98	1.06		—
		3.0~3.6V	20pF	1.59	1.54	0.65	0.67		—
		3.0~3.6V	50pF	0.76	0.72	0.32	0.32		—

**Table 29. F-type GPIO (continued)**

Parameters	Symbol	Test Voltage	Test Capacitance	Min Rise/Fall		Max Rise/Fall		Units	Notes
Output pad slew rate (low drive)	tps	1.7~1.9V	10pF	1.44	1.51	0.59	0.63	ns	—
		1.7~1.9V	20pF	0.84	0.96	0.35	0.40		—
		1.7~1.9V	50pF	0.36	0.46	0.16	0.19		—
		3.0~3.6V	10pF	1.48	1.39	0.59	0.60		—
		3.0~3.6V	20pF	0.88	0.82	0.37	0.36		—
		3.0~3.6V	50pF	0.39	0.36	0.17	0.16		—
Input pad average hysteresis	tih	1.7 V~1.9 V	—	100		75		mV	—
		3.0 V~3.6 V	—	100		50			—

Table 30 shows the CLK-type GPIO AC timing and parameters.

**Table 30. CLK-Type GPIO**

Parameters	Symbol	Test Voltage	Test Capacitance	Min Rise/Fall		Max Rise/Fall		units	Notes
Duty cycle	Fduty	—	—	—		—		%	—
Output pad transition times (maximum drive)	tpr	1.7~1.9V	10pF	0.48	0.52	1.08	1.12	ns	—
		1.7~1.9V	20pF	0.72	0.74	1.56	1.56		—
		1.7~1.9V	50pF	1.41	1.28	3.04	2.7		—
		3.0~3.6V	10pF	0.61	0.57	1.25	1.12		—
		3.0~3.6V	20pF	0.85	0.85	1.73	1.63		—
		3.0~3.6V	50pF	1.56	1.63	3.13	3.08		—
Output pad transition times (medium drive)	tpr	1.7~1.9V	10pF	0.76	0.76	1.67	1.62	ns	—
		1.7~1.9V	20pF	1.22	1.14	2.64	2.41		—
		1.7~1.9V	50pF	2.66	2.2	5.61	4.62		—
		3.0~3.6V	10pF	0.9	0.89	1.83	1.72		—
		3.0~3.6V	20pF	1.37	1.41	2.77	2.69		—
		3.0~3.6V	50pF	2.85	3.03	5.59	5.72		—
Output pad slew rate (maximum drive)	tps	1.7~1.9V	10pF	2.38	2.19	0.94	0.91	ns	—
		1.7~1.9V	20pF	1.58	1.54	0.65	0.65		—
		1.7~1.9V	50pF	0.81	0.89	0.34	0.38		—
		3.0~3.6V	10pF	3.54	3.79	1.44	1.61		—
		3.0~3.6V	20pF	2.54	2.54	1.04	1.10		—
		3.0~3.6V	50pF	1.38	1.33	0.58	0.58		—

**Table 30. CLK-Type GPIO (continued)**

Parameters	Symbol	Test Voltage	Test Capacitance	Min Rise/Fall		Max Rise/Fall		units	Notes
Output pad slew rate (medium drive)	tps	1.7~1.9V	10pF	1.50	1.50	0.61	0.63	ns	—
		1.7~1.9V	20pF	0.93	1.00	0.39	0.42		—
		1.7~1.9V	50pF	0.43	0.52	0.18	0.22		—
		3.0~3.6V	10pF	2.40	2.43	0.98	1.05		—
		3.0~3.6V	20pF	1.58	1.53	0.65	0.67		—
		3.0~3.6V	50pF	0.76	0.71	0.32	0.31		—
Input pad average hysteresis	tih	1.7 V–1.9 V	—	100		75		mV	—
		3.0 V–3.6 V	—	100		50			—

## 3.5 Module Timing and Electrical Parameters

### 3.5.1 ADC Electrical Specifications

This section describes the electrical specifications, including DC and AC information, of Low-Resolution ADC (LRADC) and High-Speed ADC (HSADC).

#### 3.5.1.1 LRADC Electrical Specifications

Table 31 shows the electrical specifications for the LRADC.

**Table 31. LRADC Electrical Specifications**

Parameter	Conditions	Min.	Typ.	Max.	Unit
<b>AC Electrical Specification</b>					
Input capacitance ( $C_p$ )	No pin/pad capacitance included	—	0.5	—	pF
Resolution	—	12			bits
Maximum sampling rate <sup>1</sup> (fs)	—	—	—	428	kHz
Power-up time <sup>2</sup>	—	1			sample cycles
<b>DC Electrical Specification</b>					
DC input voltage		0		1.85	V
Current consumption <sup>3</sup> VDDA VDDD	—	—	TBD	—	mA mA
<b>Touchscreen Interface</b>					
Expected plate resistance	—	200	—	50000	$\Omega$

<sup>1</sup> There is no sample and hold circuit in LRADC, so it is only for DC input voltage or ones with very small slope.

- <sup>2</sup> This comprises only the required initial dummy conversion cycle, NOT including the Analog part power-up time.
- <sup>3</sup> This value only includes the ADC and the driver switches, but it does not take into account the current consumption in the touchscreen plate. For example, if the plate resistance is 200 ohm, the total current consumption is about 11 mA.

### 3.5.1.2 HSADC Electrical Specification

Table 32 shows the electrical specifications for the HSADC

**Table 32. HSADC Electrical Specification**

Parameter	Conditions	Min.	Typ.	Max.	Unit
<b>AC Electrical Specification</b>					
Input sampling capacitance ( $C_s$ )	No pin/pad capacitance included	—	0.5	—	pF
Resolution	—	12			bits
Maximum sampling rate (fs)	—	—	—	2	MHz
Power-up time	—	1			sample cycles
<b>DC Electrical Specification</b>					
DC input voltage	—	0.5	—	VDDA-0.5	V
Current Consumption VDDA VDDD	—	—	TBD	—	mA mA
DNL	$f_{in} = 1 \text{ kHz}$	—	—	TBD	LSB
INL	$f_{in} = 1 \text{ kHz}$	—	—	TBD	LSB

### 3.5.2 DPLL Electrical Specifications

This section includes descriptions of the USB PLL electrical specifications and Ethernet PLL electrical specifications.

#### 3.5.2.1 USB PLL Electrical Specifications

The i.MX28 integrates a high-frequency USB PLL that provides the 480-MHz clock for the USB and other system blocks.

Table 33 lists the USB PLL output electrical specifications.

**Table 33. USB PLL Specifications**

Parameter	Test Conditions	Min	Typ	Max	Unit
PLL lock time	—	—	—	10	$\mu\text{s}$

### 3.5.2.2 Ethernet PLL Electrical Specifications

i.MX28 provides a 50-MHz/25-MHz output clock, called the Ethernet PLL output.

Table 34 lists the Ethernet PLL output electrical specifications.

**Table 34. Ethernet PLL Specifications**

Parameter	Test Conditions	Min	Typ	Max	Unit
Output Duty Cycle	—	45	50	55	%
PLL lock time	—	—	—	10	μs
Cycle to cycle jitter	—	—	25	—	ps
Clock output frequency tolerance <sup>1</sup>	—	—	—	+/-20	ppm

<sup>1</sup> This Ethernet output clock tolerance specification is the contribution from the PLL only and assumes a perfect 24 MHz clock/crystal source with 0 ppm deviation. The 24 MHz crystal frequency tolerance/deviation should be added to this number for the total Ethernet clock output frequency tolerance.

### 3.5.3 EMI AC Timing

This section includes descriptions of the electrical specifications of EMI module which interfaces external DDR2 and Mobile-DDR1 (LP-DDR1) memory devices.

#### 3.5.3.1 EMI Command & Address AC Timing

Figure 5 and Table 35 specify the timing related to the address and command pins that interfaces DDR2 and Mobile-DDR1 memory devices.

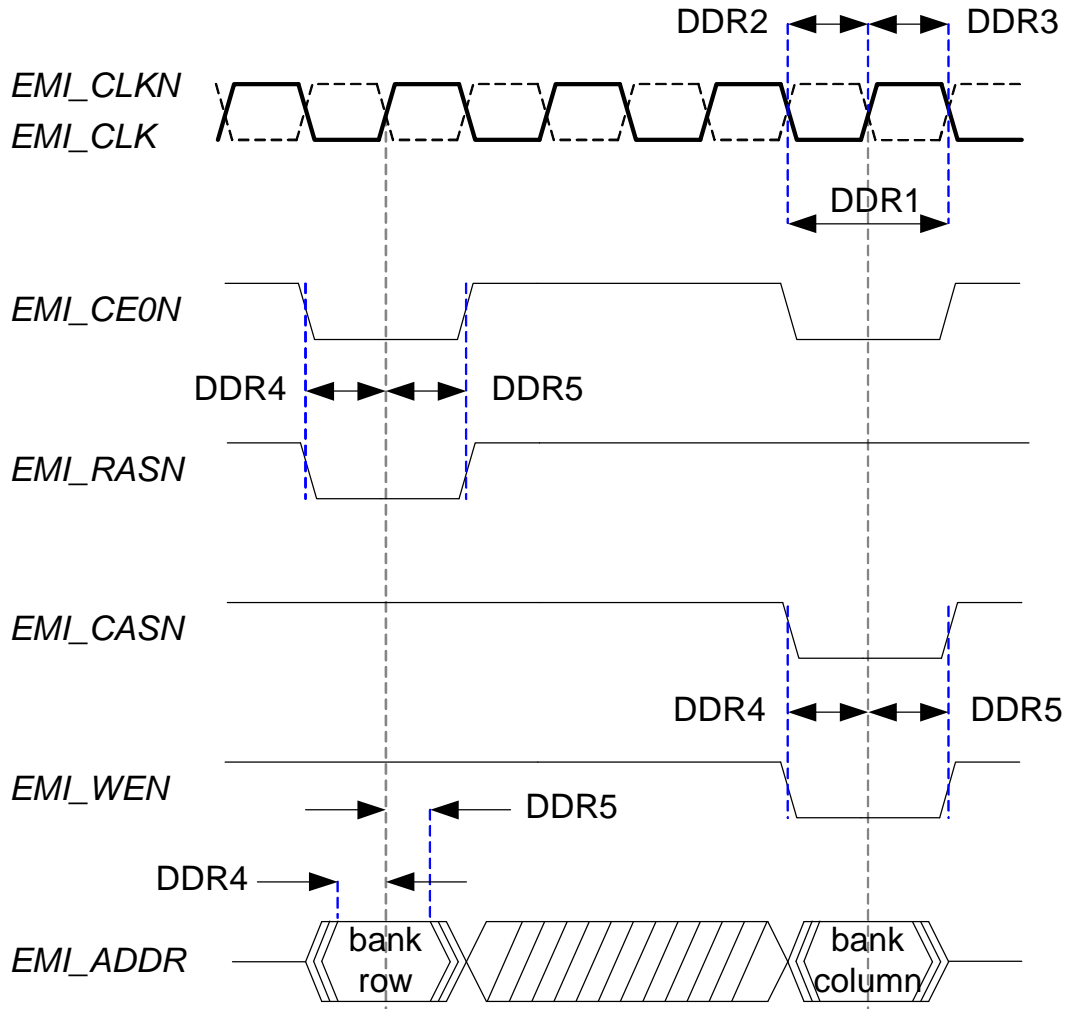


Figure 5. EMI Command/Address AC Timing

Table 35. EMI Command/Address AC Timing

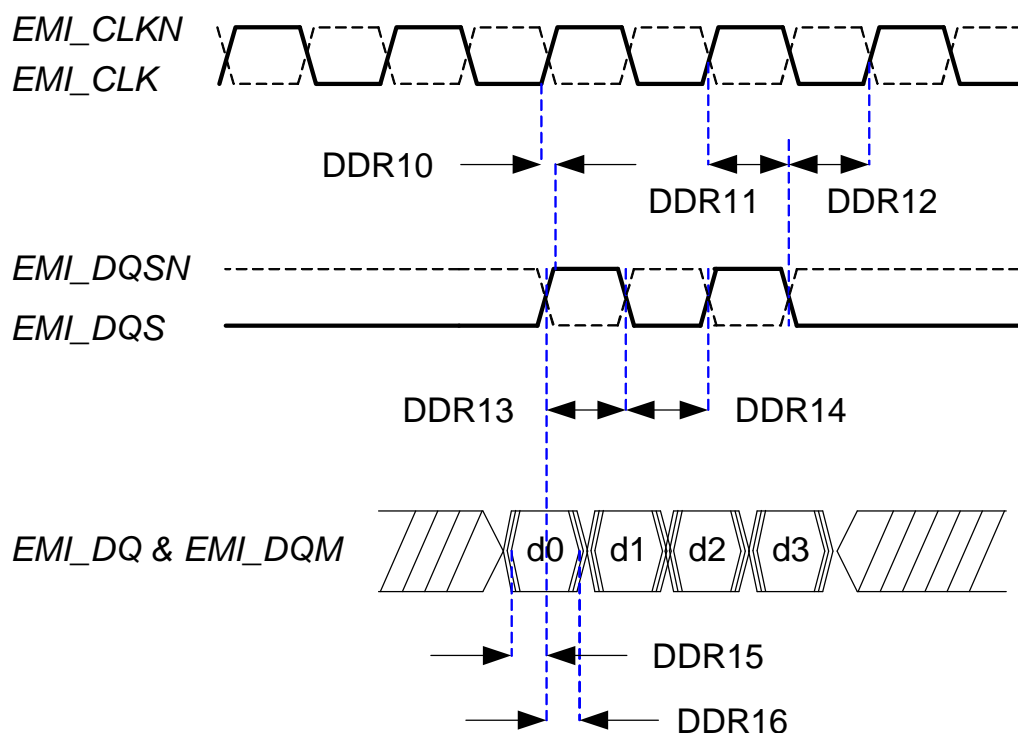
ID	Description	Symbol	Min.	Max.	Unit
DDR1	CK cycle time	tCK	4.86	—	ns
DDR2	CK high level width	tCH	0.5 tCK -0.5	0.5 tCK + 0.5	ns

**Table 35. EMI Command/Address AC Timing (continued)**

ID	Description	Symbol	Min.	Max.	Unit
DDR3	CK low level width	tCL	0.5 tCK -0.5	0.5 tCK + 0.5	ns
DDR4	Address and control output setup time	tIS	0.5 tCK - 1	0.5 tCK + 0.5	ns
DDR5	Address and control output hold time	tIH	0.5 tCK - 1	0.5 tCK + 0.5	ns

### 3.5.3.2 DDR Output AC Timing

Figure 6 and Table 36 show the DDR output AC timing defined for all DDR types: LPDDR1, standard DDR2 (1.8 V), and LVDDR2 (1.5 V)



**Figure 6. DDR Output AC Timing**

**Table 36. DDR Output AC Timing**

ID	Description	Symbol	Min	Max	Unit
DDR10	Positive DQS latching edge to associated CK edge	tDQSS	-0.5	0.5	ns
DDR11	DQS falling edge from CK rising edge—hold time	tDSH	0.5 tCK -0.5	0.5 tCK + 0.5	ns
DDR12	DQS falling edge to CK rising edge—setup time	tDSS	0.5 tCK -0.5	0.5 tCK + 0.5	ns

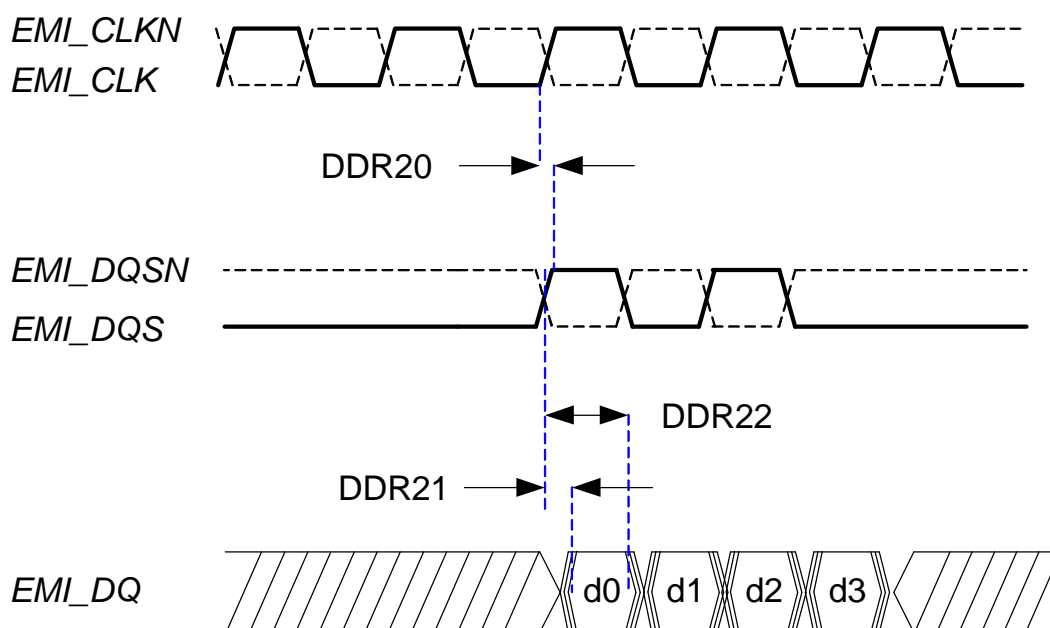


**Table 36. DDR Output AC Timing (continued)**

ID	Description	Symbol	Min	Max	Unit
DDR13	DQS output high pulse width	tDQSH	0.5 tCK -0.5	0.5 tCK + 0.5	ns
DDR14	DQS output low pulse width	tDQSL	0.5 tCK -0.5	0.5 tCK + 0.5	ns
DDR15	DQ & DQM output setup time relative to DQS	tDS	1/4 tCK -0.8	1/4 tCK -0.5	ns
DDR16	DQ & DQM output hold time relative to DQS	tDH	1/4 tCK -0.8	1/4 tCK -0.5	ns

### 3.5.3.3 DDR2 Input AC Timing

Figure 7 and Table 37 show input AC timing for standard DDR2 and LVDDR2.



**Figure 7. DDR2 Input AC Timing**

**Table 37. DDR2 Input AC Timing**

ID	Description	Symbol	Min	Max	Unit
DDR20	Positive DQS latching edge to associated CK edge	tDQSCK	-0.5	0.5	ns
DDR21	DQS to DQ input skew	tDQSQ	0.25 tCK -0.85	0.25 tCK -0.5	ns
DDR22	DQS to DQ input hold time	tQH	0.25 tCK +0.75	0.25 tCK + 1	ns

### 3.5.3.4 LPDDR1 Input AC Timing

Figure 8 and Table 38 show input AC timing for LPDDR1.

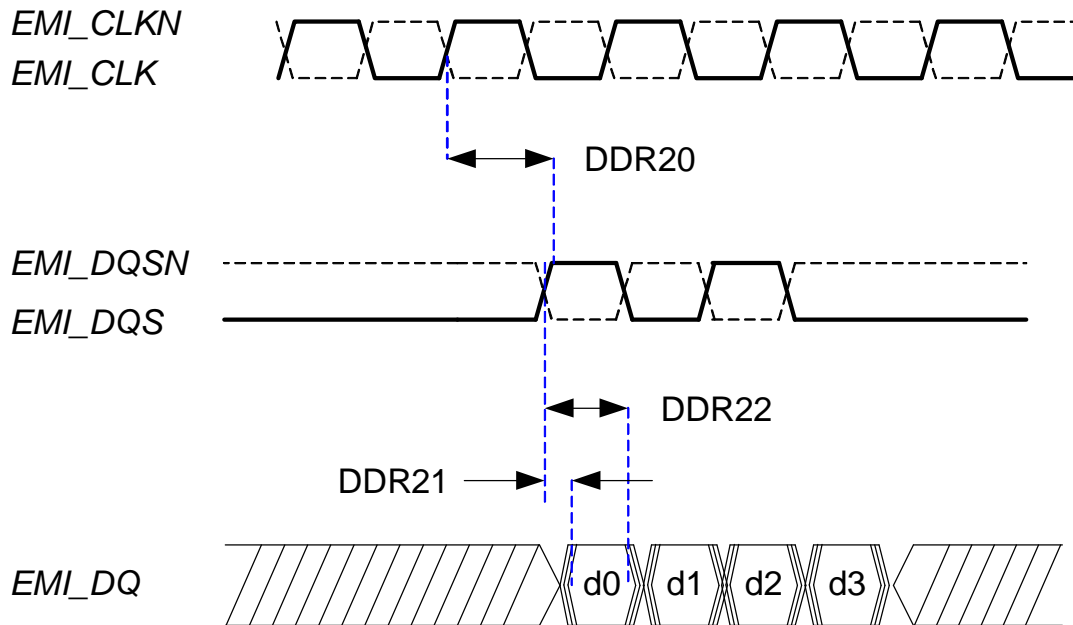


Figure 8. LPDDR1 Input AC Timing

Table 38. DDR2 Input AC Timing

ID	Description	Symbol	Min	Max	Unit
DDR20	Positive DQS latching edge to associated CK edge	tDQSCK	2	6	ns
DDR21	DQS to DQ input skew	tDQSQ	0.25 tCK -0.85	0.25 tCK -0.5	ns
DDR22	DQS to DQ input hold time	tQH	0.25 tCK +0.75	0.25 tCK + 1	ns

### 3.5.4 Ethernet MAC Controller (ENET) Timing

The ENET is designed to support both 10- and 100-Mbps Ethernet networks compliant with IEEE 802.3. An external transceiver interface and transceiver function are required to complete the interface to the media. The ENET supports 10/100-Mbps MII (18 pins altogether), 10/100-Mbps RMII (10 pins, including serial management interface), for connection to an external Ethernet transceiver. All signals are compatible with transceivers operating at a voltage of 3.3 V.

The following subsections describe the timing for MII and RMII modes.

### 3.5.4.1 ENET MII Mode Timing

This subsection describes MII receive, transmit, asynchronous inputs, and serial management signal timings.

#### 3.5.4.1.1 MII Receive Signal Timing (ENET0\_RXD[3:0], ENET0\_RX\_DV, ENET0\_RX\_ER, and ENET0\_RX\_CLK)

The receiver functions correctly up to an ENET0\_RX\_CLK maximum frequency of 25 MHz + 1%. There is no minimum frequency requirement. Additionally, the processor clock frequency must exceed twice the ENET0\_RX\_CLK frequency.

Figure 9 shows MII receive signal timings. Table 39 describes the timing parameters (M1–M4) shown in the figure.

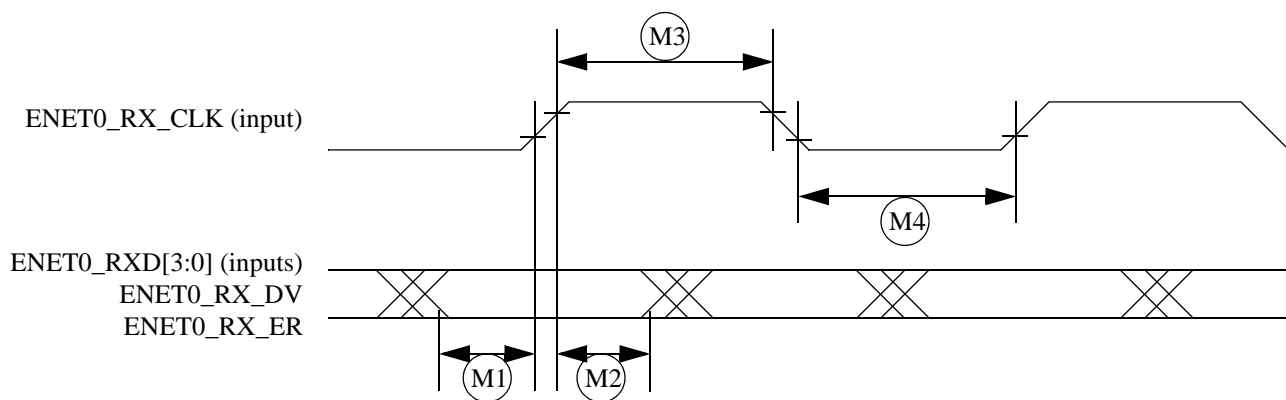


Figure 9. MII Receive Signal Timing Diagram

Table 39. MII Receive Signal Timing

ID	Characteristic <sup>1</sup>	Min.	Max.	Unit
M1	ENET0_RXD[3:0], ENET0_RX_DV, ENET0_RX_ER to ENET0_RX_CLK setup	5	—	ns
M2	ENET0_RX_CLK to ENET0_RXD[3:0], ENET0_RX_DV, ENET0_RX_ER hold	5	—	ns
M3	ENET0_RX_CLK pulse width high	35%	65%	ENET0_RX_CLK period
M4	ENET0_RX_CLK pulse width low	35%	65%	ENET0_RX_CLK period

<sup>1</sup> ENET0\_RX\_DV, ENET0\_RX\_CLK, and ENET0\_RXD0 have the same timing in 10 Mbps 7-wire interface mode.

#### 3.5.4.1.2 MII Transmit Signal Timing (ENET0\_TXD[3:0], ENET0\_TX\_EN, ENET0\_TX\_ER, and ENET0\_TX\_CLK)

The transmitter functions correctly up to an ENET0\_TX\_CLK maximum frequency of 25 MHz + 1%. There is no minimum frequency requirement. Additionally, the processor clock frequency must exceed twice the ENET0\_TX\_CLK frequency.

Figure 10 shows MII transmit signal timings. Table 40 describes the timing parameters (M5–M8) shown in the figure.

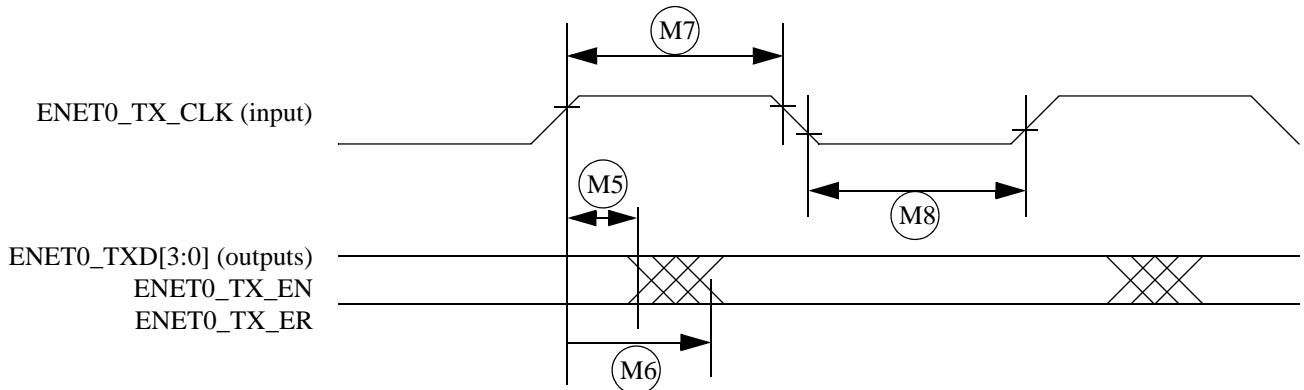


Figure 10. MII Transmit Signal Timing Diagram

Table 40. MII Transmit Signal Timing

ID	Characteristic <sup>1</sup>	Min.	Max.	Unit
M5	ENET0_TX_CLK to ENET0_TXD[3:0], ENET0_TX_EN, ENET0_TX_ER invalid	5	—	ns
M6	ENET0_TX_CLK to ENET0_TXD[3:0], ENET0_TX_EN, ENET0_TX_ER valid	—	20	ns
M7	ENET0_TX_CLK pulse width high	35%	65%	ENET0_TX_CLK period
M8	ENET0_TX_CLK pulse width low	35%	65%	ENET0_TX_CLK period

<sup>1</sup> ENET0\_TX\_EN, ENET0\_TX\_CLK, and ENET0\_TXD0 have the same timing in 10-Mbps 7-wire interface mode.

### 3.5.4.1.3 MII Asynchronous Inputs Signal Timing (ENET0\_CRIS and ENET0\_COL)

Figure 11 shows MII asynchronous input timings. Table 41 describes the timing parameter (M9) shown in the figure.

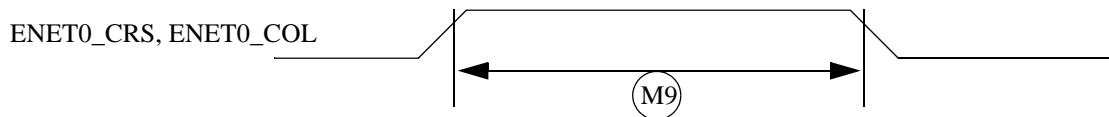


Figure 11. MII Async Inputs Timing Diagram

Table 41. MII Asynchronous Inputs Signal Timing

ID	Characteristic	Min.	Max.	Unit
M9 <sup>1</sup>	ENET0_CRIS to ENET0_COL minimum pulse width	1.5	—	ENET0_TX_CLK period

<sup>1</sup> ENET0\_COL has the same timing in 10-Mbit 7-wire interface mode.

### 3.5.4.1.4 MII Serial Management Channel Timing (ENET0\_MDIO and ENET0\_MDC)

The MDC frequency is designed to be equal to or less than 2.5 MHz to be compatible with the IEEE 802.3 MII specification. However the ENET can function correctly with a maximum MDC frequency of 15 MHz.

Figure 12 shows MII asynchronous input timings. Table 42 describes the timing parameters (M10–M15) shown in the figure.

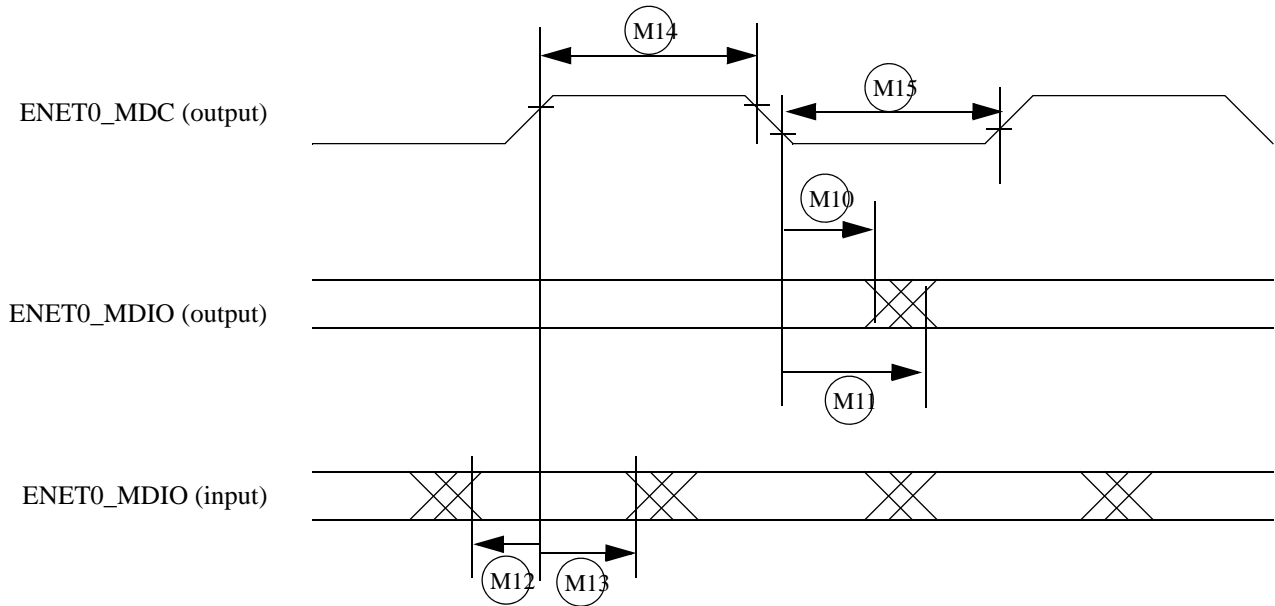


Figure 12. MII Serial Management Channel Timing Diagram

Table 42. MII Serial Management Channel Timing

ID	Characteristic	Min.	Max.	Unit
M10	ENET0_MDC falling edge to ENET0_MDIO output invalid (min. propagation delay)	0	—	ns
M11	ENET0_MDC falling edge to ENET0_MDIO output valid (max. propagation delay)	—	5	ns
M12	ENET0_MDIO (input) to ENET0_MDC rising edge setup	18	—	ns
M13	ENET0_MDIO (input) to ENET0_MDC rising edge hold	0	—	ns
M14	ENET0_MDC pulse width high	40%	60%	ENET0_MDC period
M15	ENET0_MDC pulse width low	40%	60%	ENET0_MDC period

### 3.5.4.2 RMII Mode Timing

In RMII mode, ENET\_CLK is used as the REF\_CLK, which is a 50 MHz  $\pm$  50 ppm continuous reference clock. ENET0\_RX\_DV is used as the CRS\_DV in RMII. Other signals under RMII mode include ENET0\_TX\_EN, ENET0\_TXD[1:0], ENET0\_RXD[1:0] and ENET0\_RX\_ER.

Figure 13 shows RMI mode timings. Table 43 describes the timing parameters (M16–M21) shown in the figure.

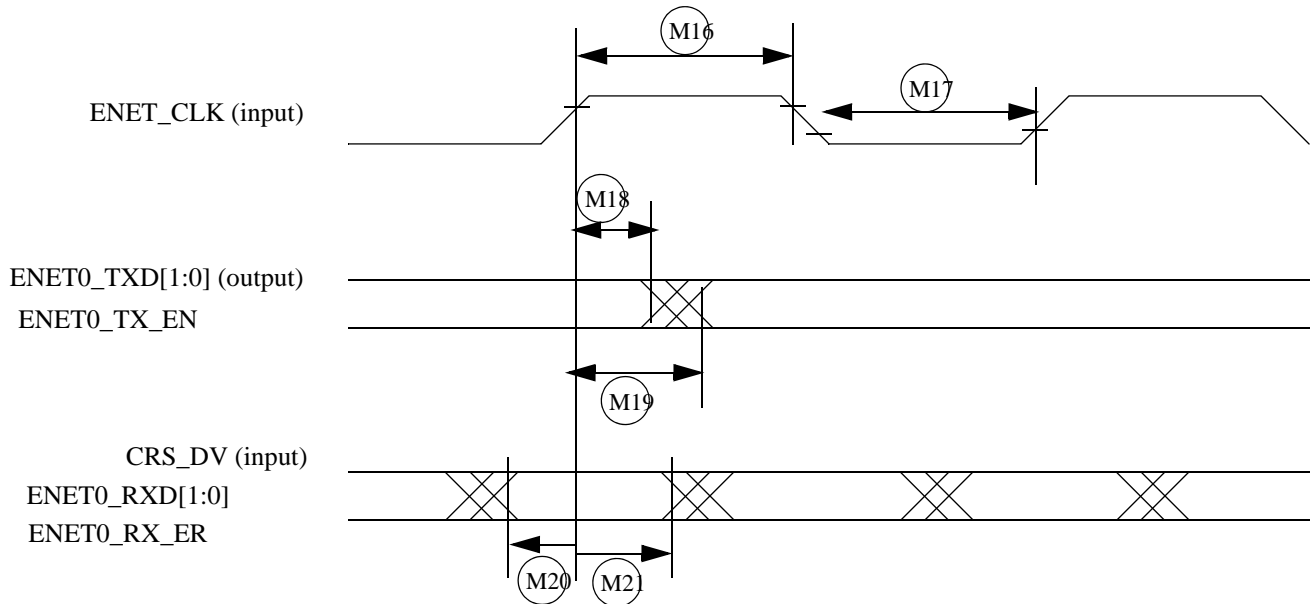


Figure 13. RMI Mode Signal Timing Diagram

Table 43. RMI Signal Timing

ID	Characteristic	Min.	Max.	Unit
M16	ENET_CLK pulse width high	35%	65%	ENET_CLK period
M17	ENET_CLK pulse width low	35%	65%	ENET_CLK period
M18	ENET_CLK to ENET0_TXD[1:0], ENET0_TX_EN invalid	3	—	ns
M19	ENET_CLK to ENET0_TXD[1:0], ENET0_TX_EN valid	—	12	ns
M20	ENET0_RXD[1:0], CRS_DV(ENET0_RX_DV), ENET0_RX_ER to ENET_CLK setup	2	—	ns
M21	ENET_CLK to ENET0_RXD[1:0], ENET0_RX_DV, ENET0_RX_ER hold	2	—	ns

### 3.5.5 Coresight ETM9 AC Interface Timing

The following timing specifications are given as a guide for a TPA that supports TRACECLK frequencies up to 80 MHz.

#### 3.5.5.1 TRACECLK Timing

This section describes TRACECLK timings.

Figure 14 shows TRACECLK signal timings. Table 44 describes the timing parameters shown in the figure.

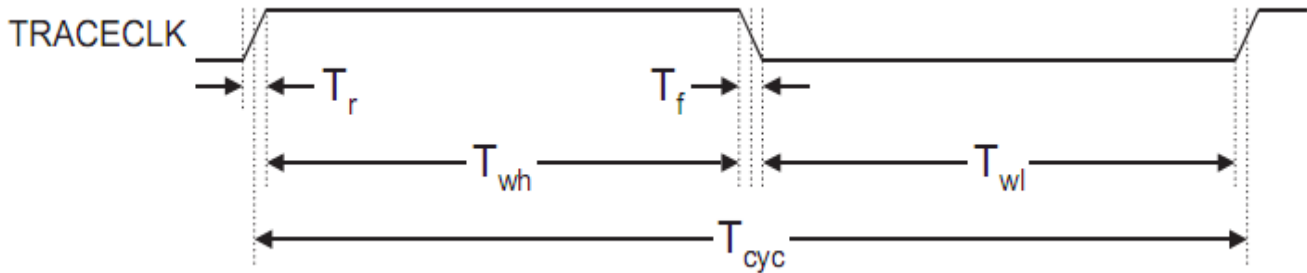


Figure 14. TRACECLK Signal Timing Diagram

Table 44. MII Receive Signal Timing

ID	Characteristic <sup>1</sup>	Min.	Max.	Unit
Tr	Clock and data raise time	3	—	ns
Tf	Clock and data fall time	3	—	ns
Twh	High pulse wide	2	—	ns
Twl	Low pulse wide	2	—	ns
Tcyc	Clock period	12.5	—	ns

### 3.5.5.2 Trace Data Signal Timing

Figure 15 shows the setup and hold requirements of the trace data pins with respect to TRACECLK. Table 45 describes the timing parameters shown in the figure.

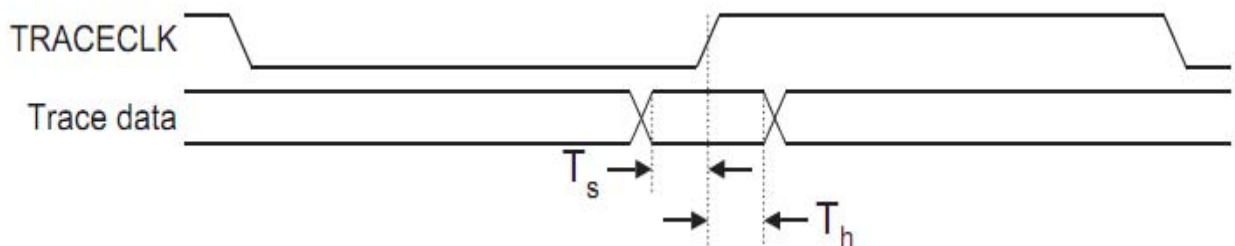


Figure 15. MII Transmit Signal Timing Diagram

Table 45. MII Transmit Signal Timing

ID	Characteristic <sup>1</sup>	Min.	Max.	Unit
Ts	Data setup	2	—	ns
Th	Data hold	2	—	ns

### 3.5.6 FlexCAN AC Timing

Table 46 and Table 47 show voltage requirements for the FlexCAN transceiver Tx and Rx pins.

**Table 46. Tx Pin Characteristics**

Parameter	Symbol	Min.	Typ.	Max.	Units
High-level output voltage	VOH	2	—	$V_{CC}^1 + 0.3$	V
Low-level output voltage	VOL	—	0.8	—	V

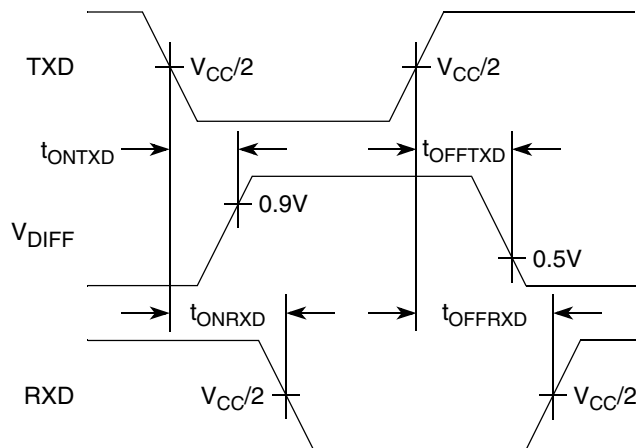
<sup>1</sup>  $V_{CC} = +3.3\text{ V} \pm 5\%$

**Table 47. Rx Pin Characteristics**

Parameter	Symbol	Min.	Typ.	Max.	Units
High-level input voltage	VIH	$0.8 \times V_{CC}^1$	—	$V_{CC}^1$	V
Low-level input voltage	VIL	—	0.4	—	V

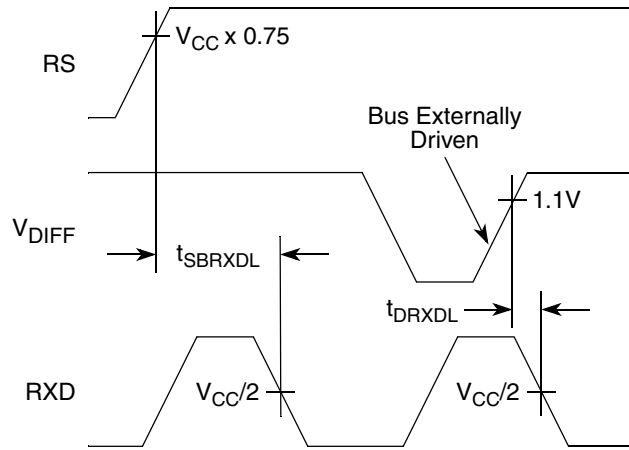
<sup>1</sup>  $V_{CC} = +3.3\text{ V} \pm 5\%$

Figure 16 through Figure 19 show the FlexCAN timing, including timing of the standby and shutdown signals.

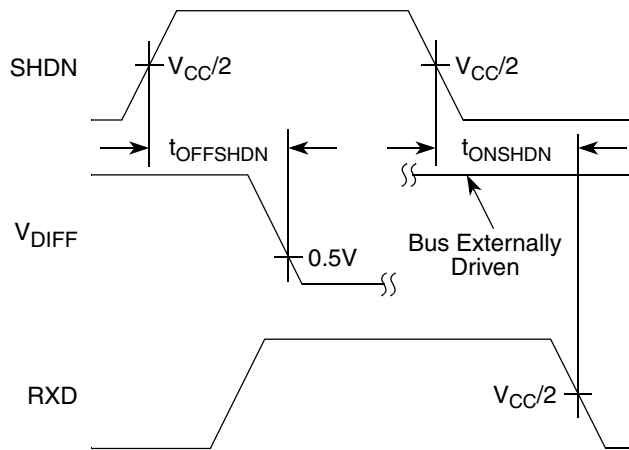


**Figure 16. FlexCAN Timing Diagram**

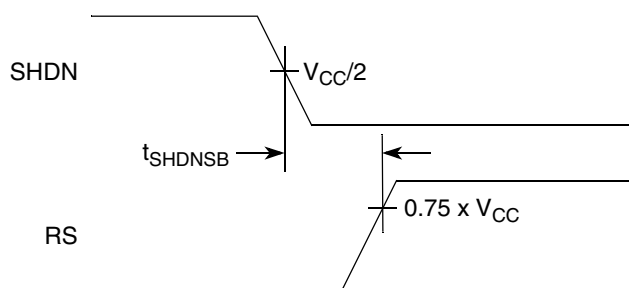




**Figure 17. Timing Diagram for FlexCAN Standby Signal**



**Figure 18. Timing Diagram for FlexCAN Shutdown Signal**



**Figure 19. Timing Diagram for FlexCAN Shutdown-to-Standby Signal**

### 3.5.7 General-Purpose Media Interface (GPMI) Timing

The i.MX28 GPMI controller is a flexible interface NAND Flash controller with 8-bit data width, up to 50MB/s I/O speed and individual chip select.

It supports normal timing mode, using two Flash clock cycles for one access of  $\overline{RE}$  and  $\overline{WE}$ . AC timings are provided as multiplications of the clock cycle and fixed delay. Figure 20, Figure 21, Figure 22 and Figure 23 depict the relative timing between GPMI signals at the module level for different operations under normal mode. Table 48 describes the timing parameters (NF1–NF17) that are shown in the figures.

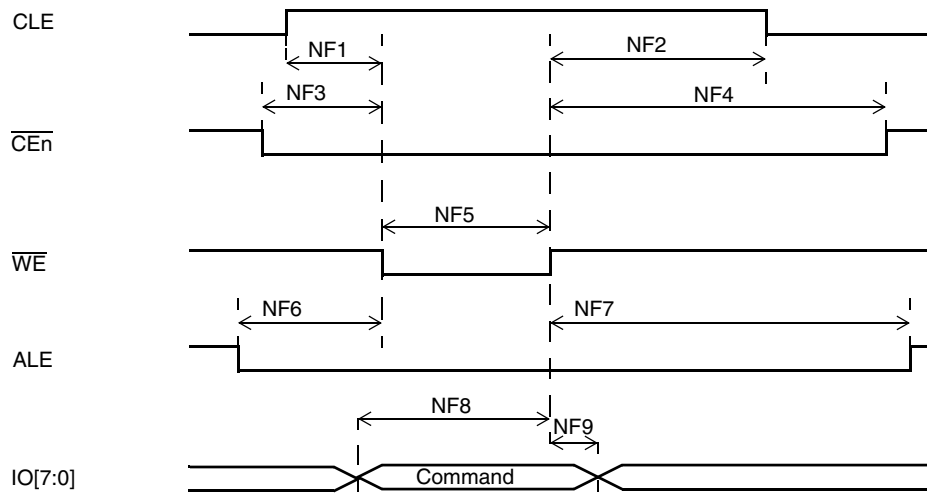


Figure 20. Command Latch Cycle Timing Diagram

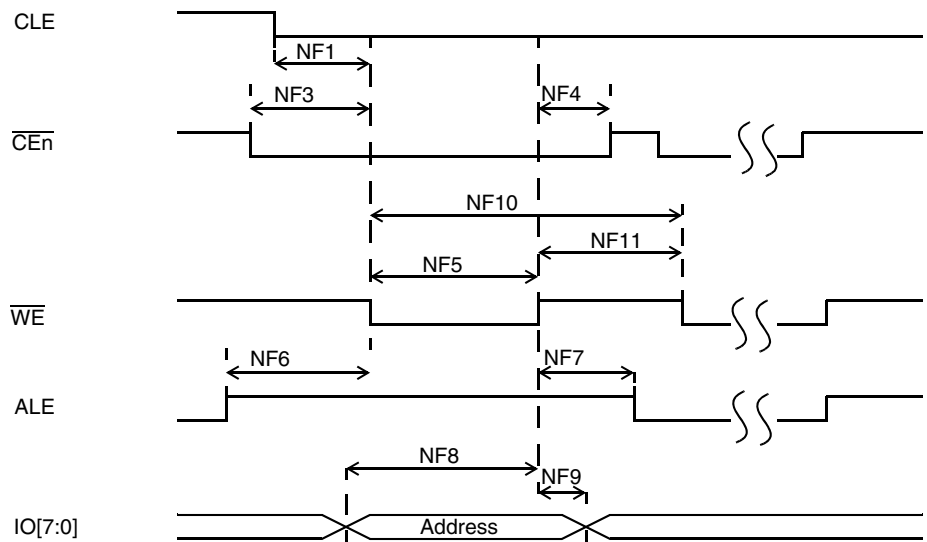
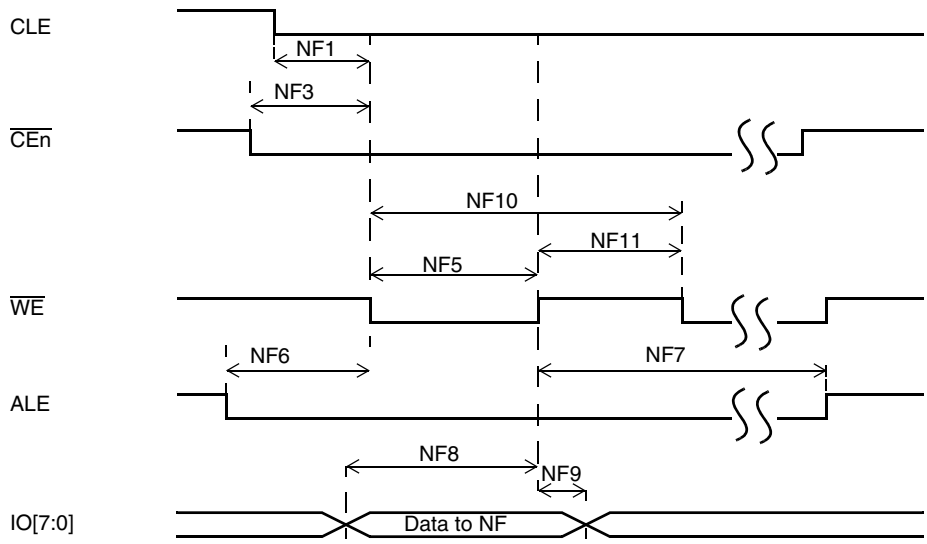
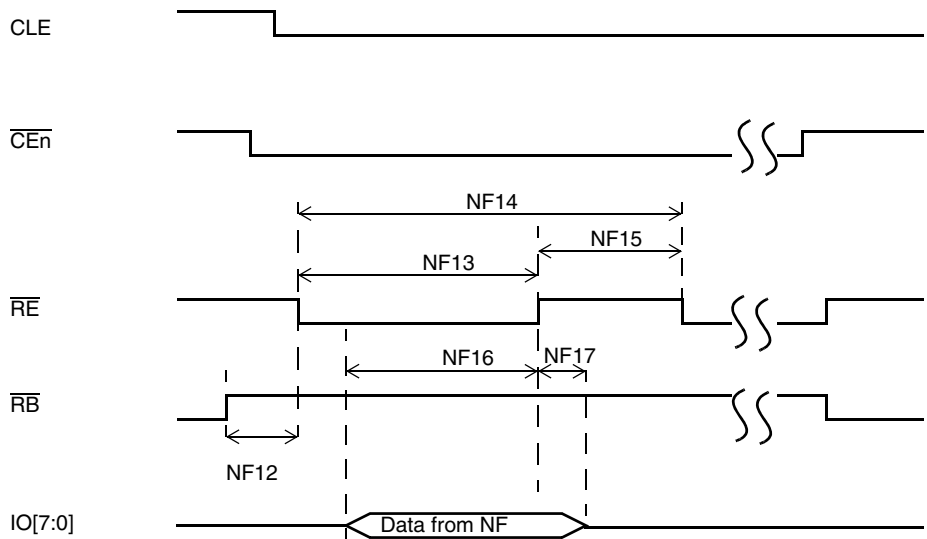


Figure 21. Address Latch Cycle Timing Diagram



**Figure 22. Write Data Latch Cycle Timing Diagram**



**Figure 23. Read Data Latch Cycle Timing Diagram**

**Table 48. NFC Timing Parameters<sup>1</sup>**

ID	Parameter	Symbol	Timing T = GPMI Clock Cycle		Example Timing for GPMI Clock $\approx$ 100MHz T = 10ns		Unit
			Min.	Max.	Min.	Max.	
NF1	CLE setup time	tCLS	(AS+1)*T	—	10	—	ns
NF2	CLE hold time	tCLH	(DH+1)*T	—	20	—	ns
NF3	$\overline{\text{CEn}}$ setup time	tCS	(AS+1)*T	—	10	—	ns
NF4	$\overline{\text{CE}}$ hold time	tCH	(DH+1)*T	—	20	—	ns
NF5	$\overline{\text{WE}}$ pulse width	tWP	DS*T		10		ns
NF6	ALE setup time	tALS	(AS+1)*T	—	10	—	ns
NF7	ALE hold time	tALH	(DH+1)*T	—	20	—	ns
NF8	Data setup time	tDS	DS*T	—	10	—	ns
NF9	Data hold time	tDH	DH*T	—	10	—	ns
NF10	Write cycle time	tWC	(DS+DH)*T		20		ns
NF11	$\overline{\text{WE}}$ hold time	tWH	DH*T		10		ns
NF12	Ready to $\overline{\text{RE}}$ low	tRR	(AS+1)*T	—	10	—	ns
NF13	$\overline{\text{RE}}$ pulse width	tRP	DS*T	—	10	—	ns
NF14	READ cycle time	tRC	(DS+DH)*T	—	20	—	ns
NF15	$\overline{\text{RE}}$ high hold time	tREH	DH*T		10	—	ns
NF16	Data setup on read	tDSR	N/A		10	—	ns
NF17	Data hold on read	tDHR	N/A		10	—	ns

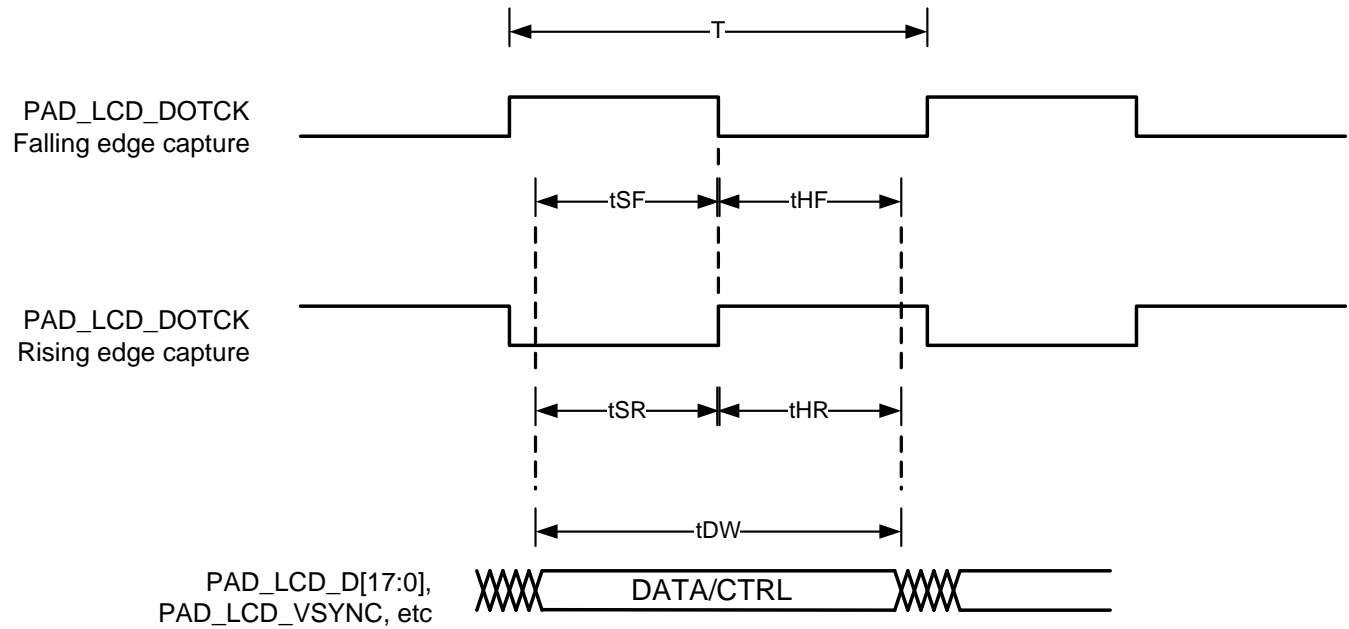
<sup>1</sup> The Flash clock maximum frequency is 100 MHz.

2)GPMI's output timing could be controlled by module's internal register, say HW\_GPMI\_TIMING0\_ADDRESS\_SETUP,HW\_GPMI\_TIMING0\_DATA\_SETUP,HW\_GPMI\_TIMING0\_DATA\_HOLD, this AC timing depends on these registers' setting. In the above table we use AS/DS/DH representing these settings each.

3)AS minimum value could be 0, while DS/DH minimum value is 1.

### 3.5.8 LCD AC Output Electrical Specifications

Figure 24 depicts the AC output timing for the LCD module. Table 49 lists the LCD module timing parameters.



**Notes:**

- T = LCD interface clock period
- I/O Drive Strength = 4mA
- I/O Voltage = 3.3V
- Cck = Capacitance load on DOTCK pad
- Cd = Capacitance load on DATA/CTRL pad

**Figure 24. LCD AC Output Timing Diagram**

**Table 49. LCD AC Output Timing Parameters**

ID	Parameter	Description
tSF	Data setup for falling edge	$DOTCK = T/2 - 1.97ns + 0.15 \cdot Cck - 0.19 \cdot Cd$
tHF	Data hold for falling edge	$DOTCK = T/2 + 0.29ns + 0.09 \cdot Cd - 0.10 \cdot Cck$
tSR	Data setup for rising edge	$DOTCK = T/2 - 2.09ns + 0.18 \cdot Cck - 0.19 \cdot Cd$
tHR	Data hold for rising edge	$DOTCK = T/2 + 0.40ns + 0.09 \cdot Cd - 0.10 \cdot Cck$
tDW	Data valid window	$tDW = T - 1.45ns$

### 3.5.9 Inter IC (I<sup>2</sup>C) Timing

The I<sup>2</sup>C module is designed to support up to 400-Kbps I<sup>2</sup>C connection compliant with I<sup>2</sup>C bus protocol. The following section describes I<sup>2</sup>C SDA and SCL signal timings.

Figure 25 shows the timing of the I<sup>2</sup>C module. Table 50 describes the I<sup>2</sup>C module timing parameters (IC1–IC11) shown in the figure.

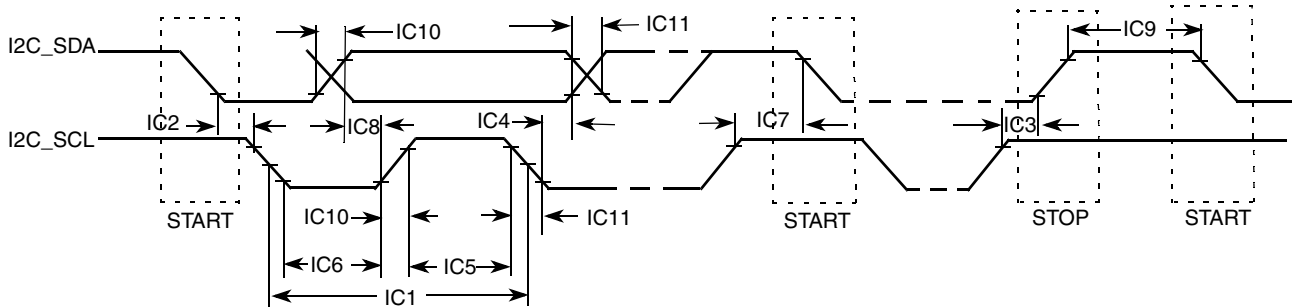


Figure 25. I<sup>2</sup>C Module Timing Diagram

Table 50. I<sup>2</sup>C Module Timing Parameters: 1.8 V – 3.6 V

ID	Parameter	Standard Mode		Fast Mode		Unit
		Min.	Max.	Min.	Max.	
IC1	I2C_SCL cycle time	10	—	2.5	—	μs
IC2	Hold time (repeated) START condition	4.0	—	0.6	—	μs
IC3	Set-up time for STOP condition	4.0	—	0.6	—	μs
IC4	Data hold time	0 <sup>1</sup>	3.45 <sup>2</sup>	0 <sup>1</sup>	0.9 <sup>2</sup>	μs
IC5	HIGH Period of I2C_SCL clock	4.0	—	0.6	—	μs
IC6	LOW Period of the I2C_SCL clock	4.7	—	1.3	—	μs
IC7	Set-up time for a repeated START condition	4.7	—	0.6	—	μs
IC8	Data set-up time	250	—	100 <sup>3</sup>	—	ns
IC9	Bus free time between a STOP and START condition	4.7	—	1.3	—	μs
IC10	Rise time of both I2C_SDA and I2C_SCL signals	—	1000	20+0.1C <sub>b</sub> <sup>4</sup>	300	ns
IC11	Fall time of both I2C_SDA and I2C_SCL signals	—	300	20+0.1C <sub>b</sub> <sup>4</sup>	300	ns
IC12	Capacitive load for each bus line (C <sub>b</sub> )	—	400	—	400	pF

<sup>1</sup> A device must internally provide a hold time of at least 300 ns for the I2C\_SDA signal in order to bridge the undefined region of the falling edge of I2C\_SCL.

<sup>2</sup> The maximum IC4 has to be met only if the device does not stretch the LOW period (ID no IC5) of the I2C\_SCL signal.

<sup>3</sup> A fast-mode I2C bus device can be used in a standard-mode I<sup>2</sup>C bus system, but the requirement of Set-up time (ID No IC7) of 250 ns must then be met. This is automatically the case if the device does not stretch the LOW period of the I2C\_SCL signal. If such a device does stretch the LOW period of the I2C\_SCL signal, it must output the next data bit to the I2C\_SDA line  $\text{max\_rise\_time (ID No IC9) + data\_setup\_time (ID No IC7) = 1000 + 250 = 1250 ns}$  (according to the standard-mode I<sup>2</sup>C bus specification) before the I2C\_SCL line is released.

<sup>4</sup> C<sub>b</sub> = total capacitance of one bus line in pF.

### 3.5.10 JTAG Interface Timing

Figure 26 through Figure 29 show respectively the test clock input, boundary scan, test access port, and TRST timings for the SJC. Table 51 describes the SJC timing parameters (SJ1–SJ13) indicated in the figures.

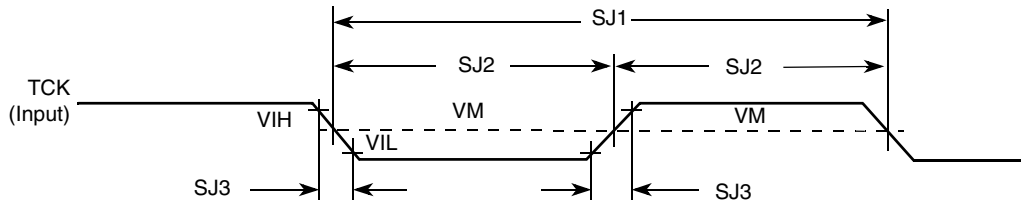


Figure 26. Test Clock Input Timing Diagram

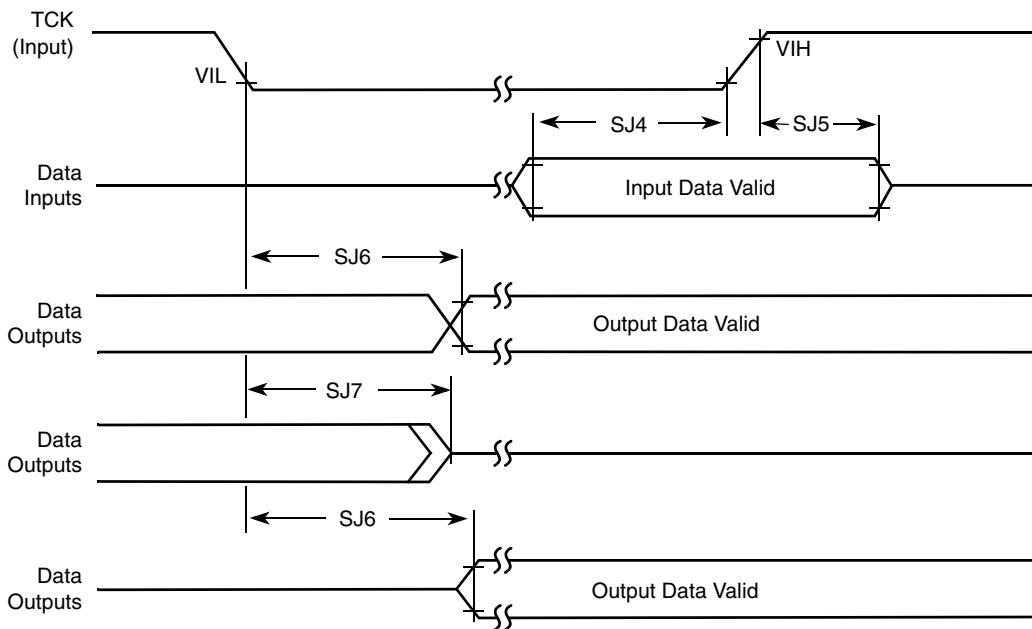


Figure 27. Boundary Scan (JTAG) Timing Diagram

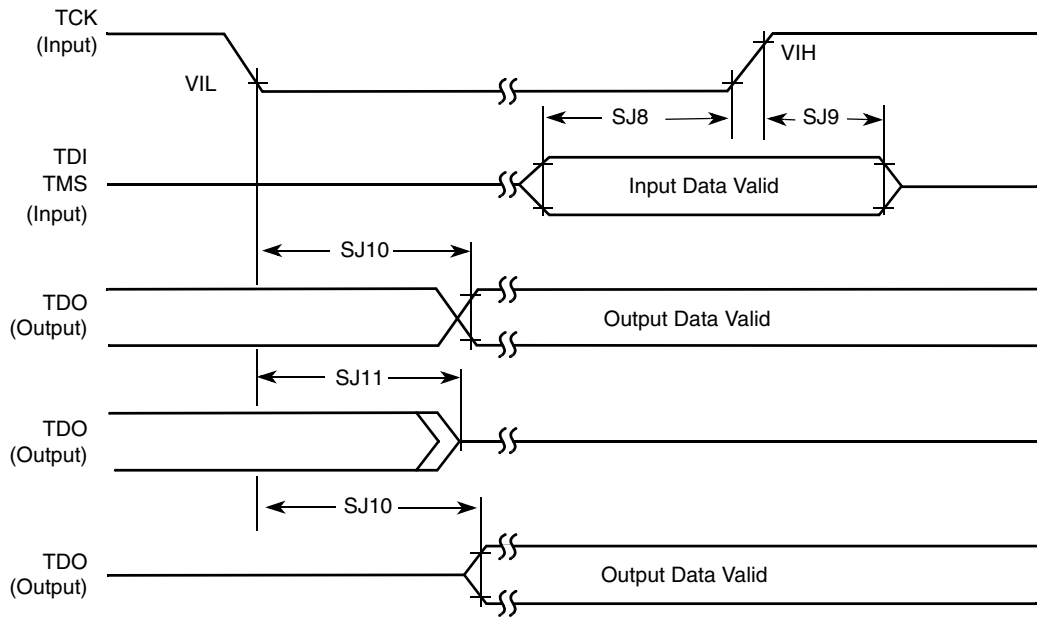


Figure 28. Test Access Port Timing Diagram

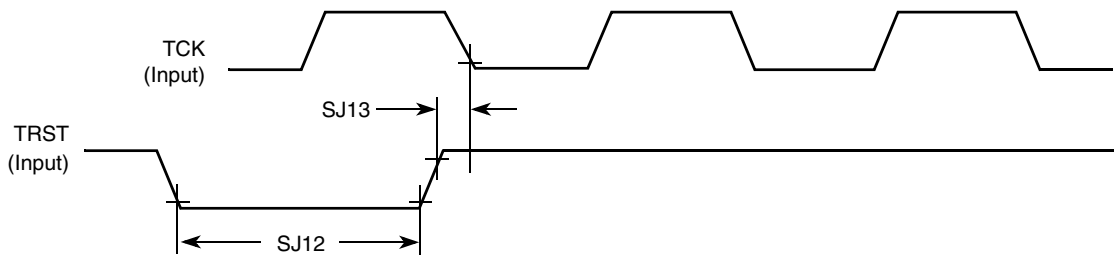


Figure 29. TRST Timing Diagram

Table 51. SJC Timing Parameters

ID	Parameter	All Frequencies		Unit
		Min.	Max.	
SJ1	TCK cycle time	100	—	ns
SJ2	TCK clock pulse width measured at $V_M^1$	40	—	ns
SJ3	TCK rise and fall times	—	3	ns
SJ4	Boundary scan input data set-up time	10	—	ns
SJ5	Boundary scan input data hold time	50	—	ns
SJ6	TCK low to output data valid	—	50	ns
SJ7	TCK low to output high impedance	—	50	ns
SJ8	TMS, TDI data set-up time	10	—	ns
SJ9	TMS, TDI data hold time	50	—	ns



**Table 51. SJC Timing Parameters (continued)**

ID	Parameter	All Frequencies		Unit
		Min.	Max.	
SJ10	TCK low to TDO data valid	—	44	ns
SJ11	TCK low to TDO high impedance	—	44	ns
SJ12	$\overline{\text{TRST}}$ assert time	100	—	ns
SJ13	$\overline{\text{TRST}}$ set-up time to TCK low	40	—	ns

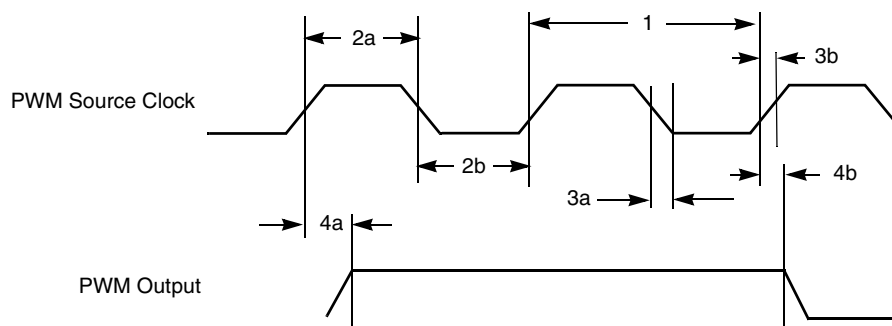
<sup>1</sup>  $V_M$  - mid point voltage

### 3.5.11 Pulse Width Modulator (PWM) Timing

Figure 30 depicts the timing of the PWM, and Table 52 lists the PWM timing characteristics.

The PWM can be programmed to select one of two clock signals as its source frequency: xtal clock or hsadc clock. The selected clock signal is passed through a prescaler before being input to the counter. The output is available at the pulse width modulator output (PWMO) external pin.

PWM also supports MATT mode. In this mode, it can be programmed to select one of two clock signals as its source frequency, 24-MHz or 32-KHz crystal clock. For a 32-KHz source clock input, the PWM outputs the 32-KHz clock directly to PAD.



**Figure 30. PWM Timing**

**Table 52. PWM Output Timing Parameter: Xtal clock**

Ref No.	Parameter	Minimum	Maximum	Unit
1	System CLK frequency <sup>1</sup>	0	24MHz	MHz
2a	Clock high time	21	—	ns
2b	Clock low time	21	—	ns
3a	Clock fall time	—	0.3	ns
3b	Clock rise time	—	0.3	ns
4a	Output delay time	—	15.08	ns
4b	Output setup time	15.77	—	ns

<sup>1</sup> CL of PWMO = 30 pF

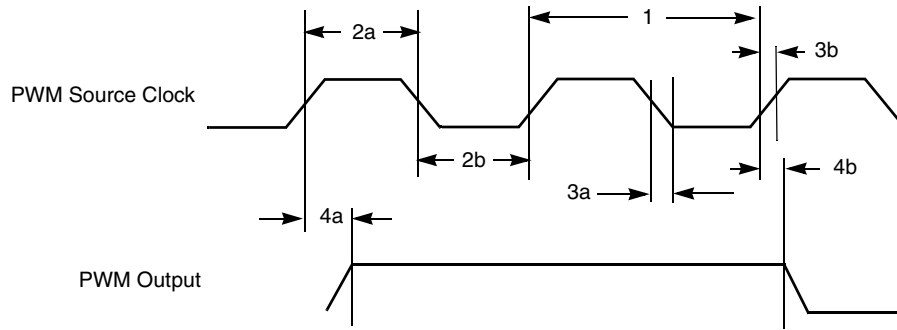


Figure 31. PWM Timing

Table 53. PWM Output Timing Parameter: HSADC clock

Ref No.	Parameter	Minimum	Maximum	Unit
1	System CLK frequency <sup>1</sup>	0	32	MHz
2a	Clock high time	6.813	—	ns
2b	Clock low time	24.432	—	ns
3a	Clock fall time	—	0.3	ns
3b	Clock rise time	—	0.3	ns
4a	Output delay time	—	14.93	ns
4b	Output setup time	15.71	—	ns

<sup>1</sup> CL of PWMO = 30 pF

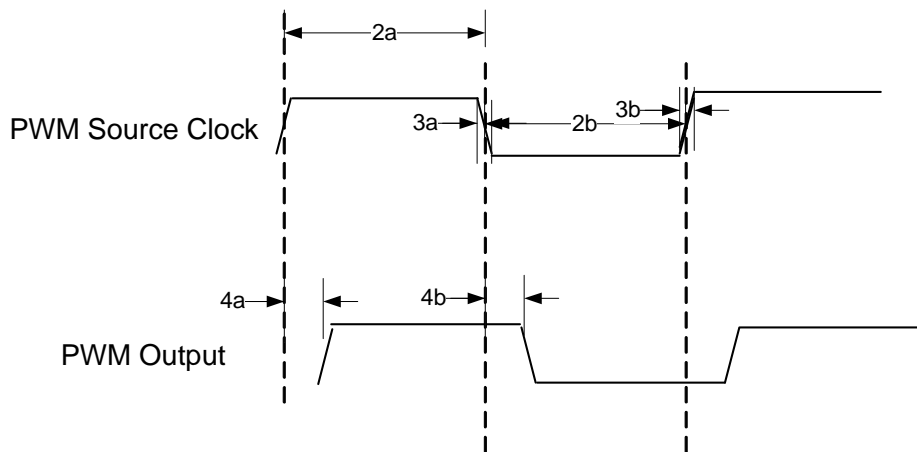


Figure 32. PWM Timing

**Table 54. PWM Output Timing Parameter: MATT Mode 24 MHz Crystal Clock**

Ref No.	Parameter	Minimum	Maximum	Unit
1	System CLK frequency <sup>1</sup>	24	24	MHz
2a	Clock high time	20.99	—	ns
2b	Clock low time	21.01	—	ns
3a	Clock fall time	—	0.3	ns
3b	Clock rise time	—	0.3	ns
4a	Output delay time	—	15.23	ns
4b	Output setup time	15.92	—	ns

<sup>1</sup> CL of PWMO = 30 pF

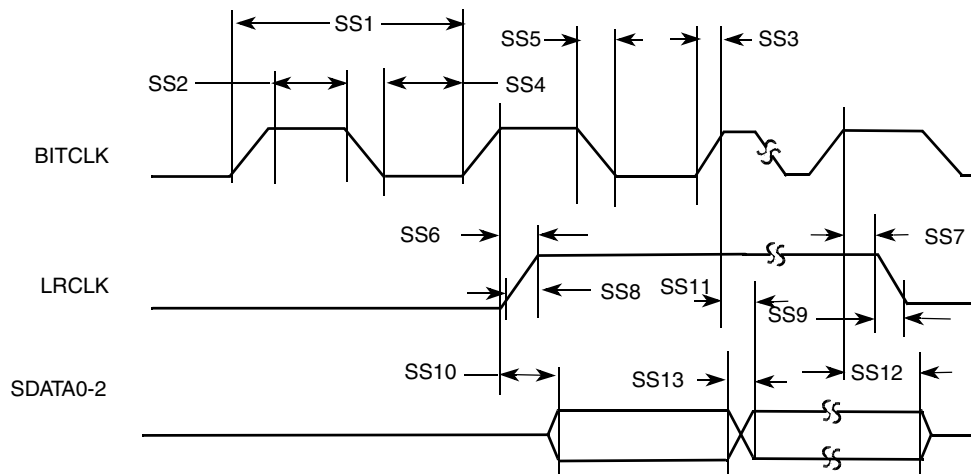
### 3.5.12 Serial Audio Interface (SAIF) AC Timing

The following subsections describe SAIF timing in two cases:

- Transmitter
- Receiver

#### 3.5.12.1 SAIF Transmitter Timing

Figure 33 shows the timing for SAIF transmitter with internal clock, and Table 55 describes the timing parameters (SS1–SS13).



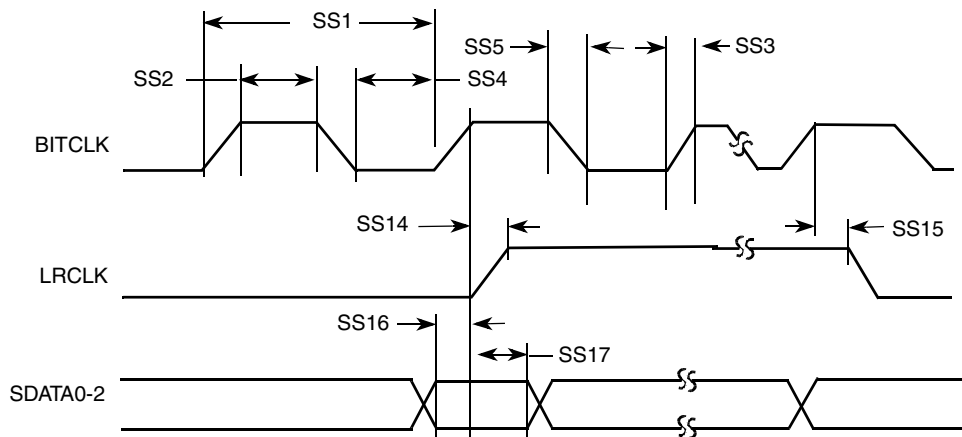
**Figure 33. SAIF Transmitter Timing Diagram**

**Table 55. SAIF Transmitter Timing**

ID	Parameter	Min.	Max.	Unit
SS1	BITCLK period	81.4	—	ns
SS2	BITCLK high period	36.0	—	ns
SS3	BITCLK rise time	—	6.0	ns
SS4	BITCLK low period	36.0	—	ns
SS5	BITCLK fall time	—	6.0	ns
SS6	BITCLK high to LRCLK high	—	15.0	ns
SS7	BITCLK high to LRCLK low	—	15.0	ns
SS8	LRCLK rise time	—	6.0	ns
SS9	LRCLK fall time	—	6.0	ns
SS10	BITCLK high to SDATA valid from high impedance	—	15.0	ns
SS11	BITCLK high to SDATA high/low	—	15.0	ns
SS12	BITCLK high to SDATA high impedance	—	15.0	ns
SS13	SDATA rise/fall time	—	6.0	ns

### 3.5.12.1.5 SAIF Receiver Timing

Figure 34 shows the timing for the SAIF receiver with internal clock. Table 56 describes the timing parameters (SS1–SS17) shown in the figure.



**Figure 34. SAIF Receiver Timing Diagram**

**Table 56. SAIF Receiver Timing with Internal Clock**

ID	Parameter	Min.	Max.	Unit
SS1	BITCLK period	81.4	—	ns
SS2	BITCLK high period	36.0	—	ns
SS3	BITCLK rise time	—	6.0	ns
SS4	BITCLK low period	36.0	—	ns
SS5	BITCLK fall time	—	6.0	ns
SS14	BITCLK high to LRCLK high	—	15.0	ns
SS15	BITCLK high to LRCLK low	—	15.0	ns
SS16	SDATA setup time before BITCLK high	10.0	—	ns
SS17	SDATA hold time after BITCLK high	0.0	—	ns

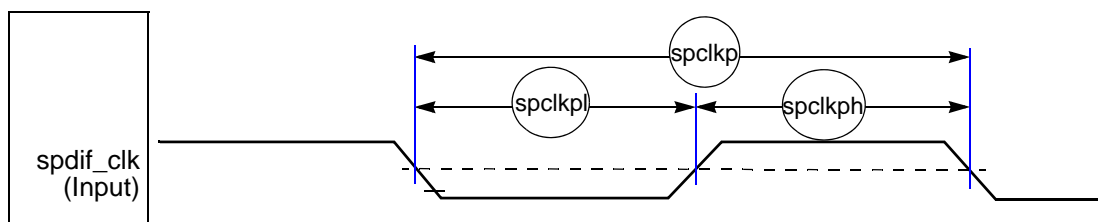
### 3.5.13 SPDIF AC Timing

SPDIF data is sent using bi-phase marking code. When encoding, the SPDIF data signal is modulated by a clock that is twice the bit rate of the data signal.

The following [Table 57](#) shows SPDIF timing parameters, including the timing of the modulating Tx clock (spdif\_clk) in SPDIF transmitter as shown in the [Figure 35](#).

**Table 57. SPDIF Timing**

Characteristics	Symbol	Timing Parameter Range		Unit
		Min	Max	
SPDIFOUT output (Load = 30pf)	—	—	—	ns
• Skew	—	—	1.5	
• Transition Rising	—	—	13.6	
• Transition Falling	—	—	18.0	
Modulating Tx clock (spdif_clk) period	spclkp	81.4	—	ns
spdif_clk high period	spclkph	65.1	—	ns
spdif_clk low period	spclkpl	65.1	—	ns



**Figure 35. spdif\_clk Timing**

### 3.5.14 Synchronous Serial Port (SSP) AC Timing

This section describes the electrical information of the SSP, which includes SD/MMC4.3 (Single Data Rate) timing, MMC4.4 (Dual Data Rate) timing, MS (Memory Stick) timing, and SPI timing.

#### 3.5.14.1 SD/MMC4.3 (Single Data Rate) AC Timing

Figure 36 depicts the timing of SD/MMC4.3, and Table 58 lists the SD/MMC4.3 timing characteristics.

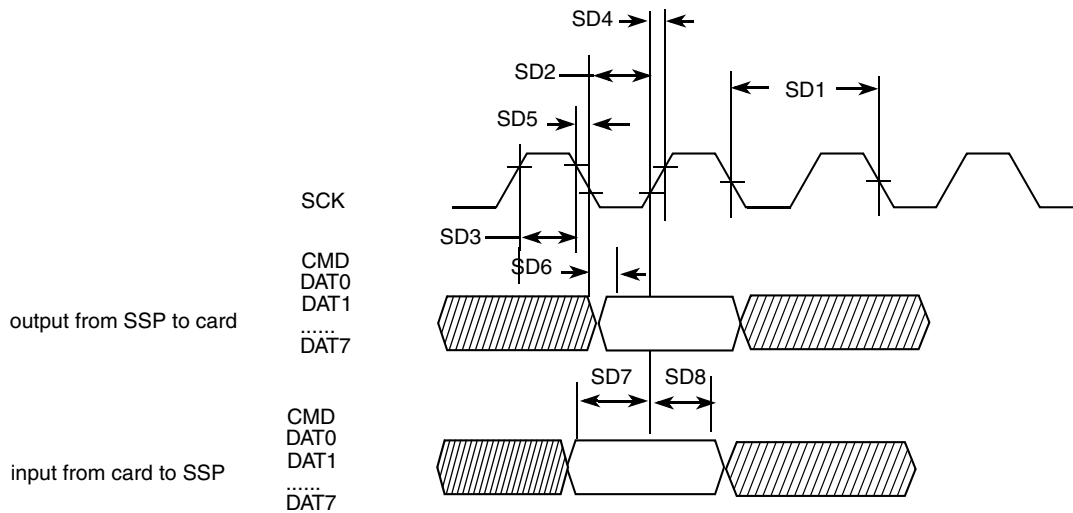


Figure 36. SD/MMC4.3 Timing

Table 58. SD/MMC4.3 Interface Timing Specification

ID	Parameter	Symbols	Min	Max	Unit
<b>Card Input Clock</b>					
SD1	Clock Frequency (Low Speed)	$f_{PP}^1$	0	400	kHz
	Clock Frequency (SD/SDIO Full Speed/High Speed)	$f_{PP}^2$	0	25/50	MHz
	Clock Frequency (MMC Full Speed/High Speed)	$f_{PP}^3$	0	20/52	MHz
	Clock Frequency (Identification Mode)	$f_{OD}$	100	400	kHz
SD2	Clock Low Time	$t_{WL}$	7	—	ns
SD3	Clock High Time	$t_{WH}$	7	—	ns
SD4	Clock Rise Time	$t_{TLH}$	—	3	ns
SD5	Clock Fall Time	$t_{THL}$	—	3	ns
<b>SSP Output / Card Inputs CMD, DAT (Reference to CLK)</b>					
SD6	SSP Output Delay	$t_{OD}$	-5	5	ns
<b>SSP Input / Card Outputs CMD, DAT (Reference to CLK)</b>					

**Table 58. SD/MMC4.3 Interface Timing Specification (continued)**

ID	Parameter	Symbols	Min	Max	Unit
SD7	SSP Input Setup Time	$t_{ISU}$	2.5	—	ns
SD8	SSP Input Hold Time	$t_{IH}^4$	2.5	—	ns

<sup>1</sup> In low speed mode, the card clock must be lower than 400 kHz, and the voltage ranges from 2.7 to 3.6 V.

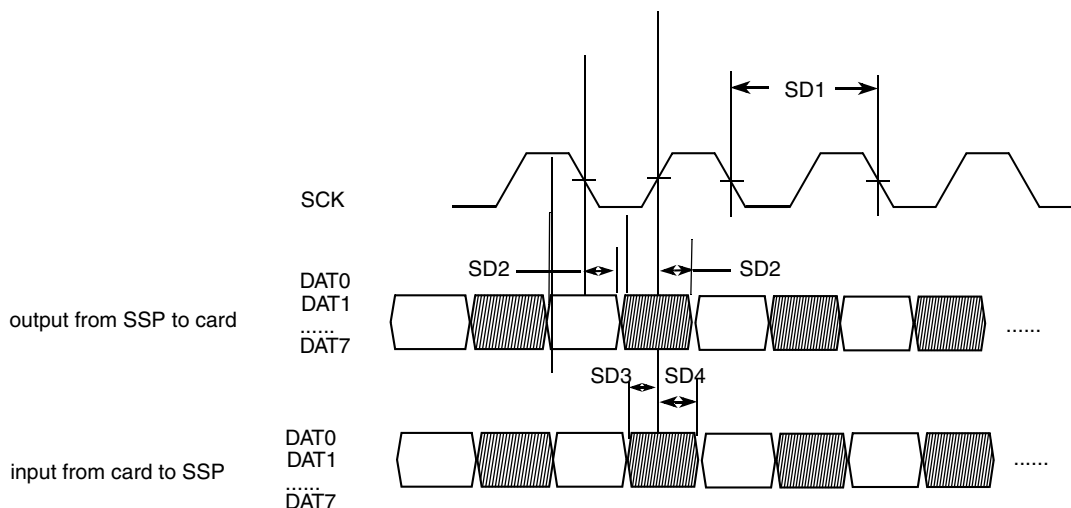
<sup>2</sup> In normal speed mode for the SD/SDIO card, clock frequency can be any value between 0 ~ 25 MHz. In high speed mode, clock frequency can be any value between 0 ~ 50 MHz.

<sup>3</sup> In normal speed mode for MMC card, clock frequency can be any value between 0 ~ 20 MHz. In high speed mode, clock frequency can be any value between 0 ~ 52MHz.

<sup>4</sup> To satisfy hold timing, the delay difference between clock input and cmd/data input must not exceed 2ns.

### 3.5.14.2 MMC4.4 (Dual Data Rate) AC Timing

Figure 37 depicts the timing of MMC4.4, and Table 59 lists the MMC4.4 timing characteristics. Be aware that only DATA0–DATA7 are sampled on both edges of the clock (not applicable to CMD).



**Figure 37. MMC4.4 Timing**

**Table 59. MMC4.4 Interface Timing Specification**

ID	Parameter	Symbols	Min	Max	Unit
<b>Card Input Clock</b>					
SD1	Clock Frequency (MMC Full Speed/High Speed)	$f_{PP}$	0	52	MHz
<b>SSP Output / Card Inputs CMD, DAT (Reference to CLK)</b>					
SD2	SSP Output Delay	$t_{OD}$	-5	5	ns
<b>SSP Input / Card Outputs CMD, DAT (Reference to CLK)</b>					
SD3	SSP Input Setup Time	$t_{ISU}$	2.5	—	ns
SD4	SSP Input Hold Time	$t_{IH}$	2.5	—	ns

### 3.5.14.3 MS (Memory Stick) AC Timing

The SSP module, which also has the function of a memory stick host controller, is compatible with the Sony Memory Stick version 1.x and Memory Stick PRO.

Figure 38, Figure 39 and Table 40 show the timing of the Memory Stick. Table 60 and Table 61 list the Memory Stick timing characteristics.

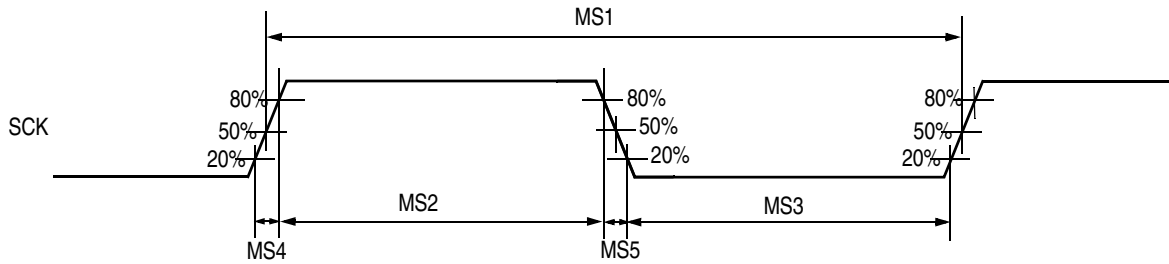


Figure 38. MS Clock Time Waveforms

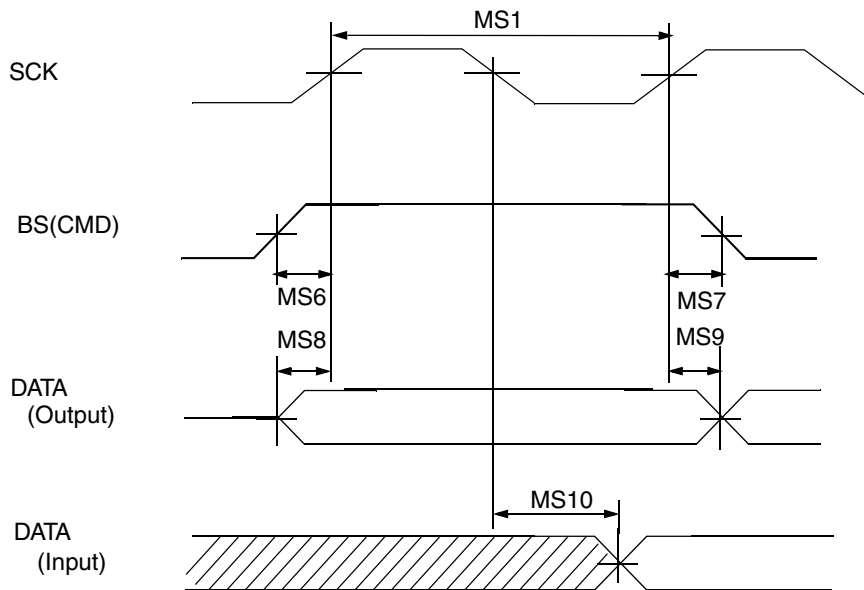
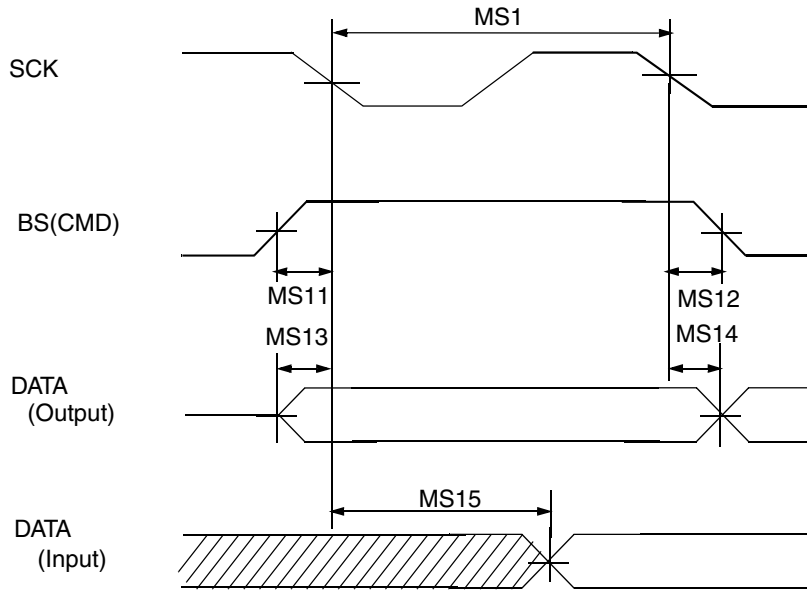


Figure 39. MS Serial Transfer Mode Timing Diagram





**Figure 40. MS Parallel Transfer Mode Timing Diagram**

**Table 60. MS Serial Transfer Timing Parameters**

ID	Parameter	Symbol	Min	Max	Units
MS1	SCK Cycle Time	tCLKc	50	—	ns
MS2	SCK High Pulse Time	tCLKwh	15	—	ns
MS3	SCK Low Pulse Time	tCLKwl	15	—	ns
MS4	SCK Rise Time	tCLKr	—	10	ns
MS5	SCK Fall Time	tCLKf	—	10	ns
MS6	BS Setup Time	tBSsu	5	—	ns
MS7	BS Hold Time	tBSsh	5	—	ns
MS8	DATA Setup Time	tDsu	5	—	ns
MS9	DATA Hold Time	tDh	5	—	ns
MS10	DATA Input Delay Time	tDd	—	15	ns

**Table 61. MS Parallel Transfer Timing Parameters**

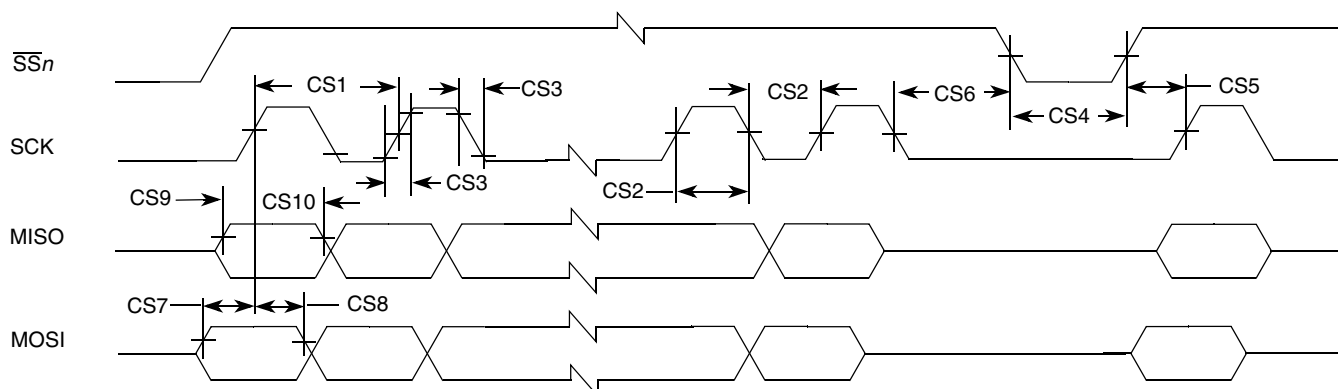
ID	Parameter	Symbol	Min	Max	Units
MS1	SCK Cycle Time	tCLKc	25	—	ns
MS2	SCK High Pulse Time	tCLKwh	5	—	ns
MS3	SCK Low Pulse Time	tCLKwl	5	—	ns

**Table 61. MS Parallel Transfer Timing Parameters (continued)**

ID	Parameter	Symbol	Min	Max	Units
MS4	SCK Rise Time	tCLKr	—	10	ns
MS5	SCK Fall Time	tCLKf	—	10	ns
MS11	BS Setup Time	tBSsu	8	—	ns
MS12	BS Hold Time	tBSH	1	—	ns
MS13	DATA Setup Time	tDsu	8	—	ns
MS14	DATA Hold Time	tDh	1	—	ns
MS15	DATA Input Delay Time	tDd	—	15	ns

### 3.5.14.4 SPI AC Timing

Figure 41 depicts the master mode and slave mode timings of the SPI, and Table 62 lists the timing parameters.



**Figure 41. SPI Interface Timing Diagram**

**Table 62. SPI Interface Timing Parameters**

ID	Parameter	Symbol	Min.	Max.	Units
CS1	SCK cycle time	t <sub>clk</sub>	50	—	ns
CS2	SCK high or low time	t <sub>sw</sub>	25	—	ns
CS3	SCK rise or fall	t <sub>RISE/FALL</sub>	—	7.6	ns
CS4	$\overline{SSn}$ pulse width	t <sub>CSLH</sub>	25	—	ns
CS5	$\overline{SSn}$ lead time (CS setup time)	t <sub>SCS</sub>	25	—	ns
CS6	$\overline{SSn}$ lag time (CS hold time)	t <sub>HCS</sub>	25	—	ns
CS7	MOSI setup time	t <sub>Smosi</sub>	5	—	ns
CS8	MOSI hold time	t <sub>Hmosi</sub>	5	—	ns
CS9	MISO setup time	t <sub>Smiso</sub>	5	—	ns
CS10	MISO hold time	t <sub>Hmiso</sub>	5	—	ns

### 3.5.15 UART (UARTAPP and DebugUART) AC Timing

This section describes the UART module AC timing which is applicable to both UARTAPP and DebugUART.

#### 3.5.15.1 UART Transmit Timing

Figure 39 shows the UART transmit timing, showing only eight data bits and one stop bit. Table 63 describes the timing parameter (UA1) shown in the figure.

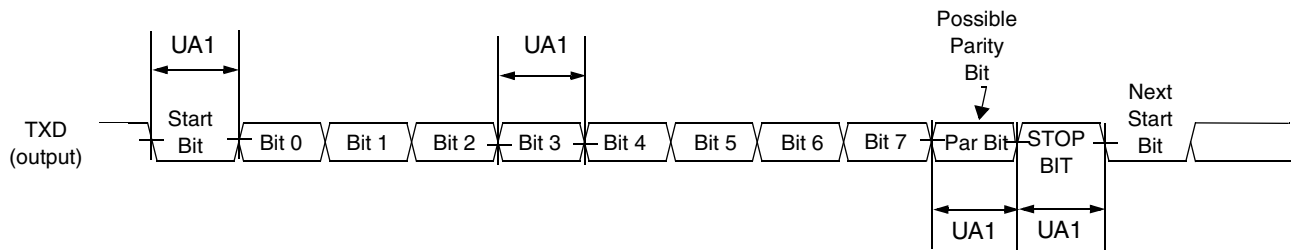


Figure 42. UART Transmit Timing Diagram

Table 63. UART Transmit Timing Parameters

ID	Parameter	Symbol	Min.	Max.	Units
UA1	Transmit Bit Time	$t_{Tbit}$	$1/F_{baud\_rate}^1 - T_{ref\_clk}^2$	$1/F_{baud\_rate} + T_{ref\_clk}$	—

<sup>1</sup>  $F_{baud\_rate}$ : Baud rate frequency. The maximum baud rate the UARTAPP can support is 3.25 Mbps. The maximum baud rate of DebugUART is 115.2 kbps.

<sup>2</sup>  $T_{ref\_clk}$ : The period of UART reference clock  $ref\_clk$  (which is APBX clock = 24 MHz).

#### 3.5.15.2 UART Receive Timing

Figure 43 shows the UART receive timing, showing only eight data bits and one stop bit. Table 64 describes the timing parameter (UA2) shown in the figure.

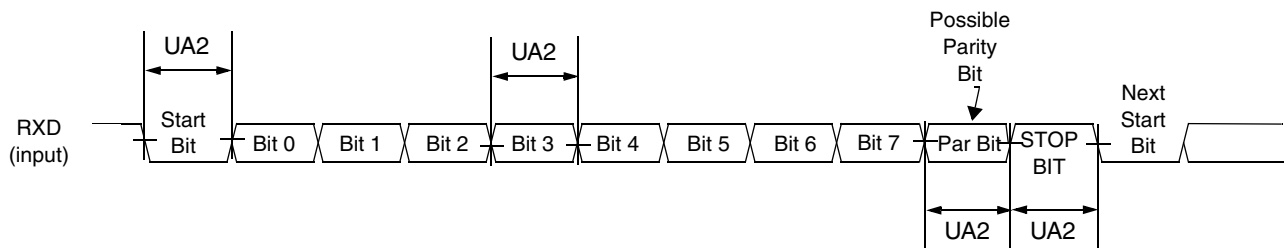


Figure 43. UART Receive Timing Diagram

**Table 64. UART Receive Timing Parameters**

ID	Parameter	Symbol	Min.	Max.	Units
UA2	Receive bit time <sup>1</sup>	$t_{Rbit}$	$1/F_{baud\_rate}^2 - 1/(16 \times F_{baud\_rate})$	$1/F_{baud\_rate} + 1/(16 \times F_{baud\_rate})$	—

<sup>1</sup> The UART receiver can tolerate  $1/(16 \times F_{baud\_rate})$  tolerance in each bit. But accumulation tolerance in one frame must not exceed  $3/(16 \times F_{baud\_rate})$ .

<sup>2</sup>  $F_{baud\_rate}$ : Baud rate frequency. The maximum baud rate the UARTAPP can support is 3.25 Mbps. The maximum baud rate of DebugUART is 115 kbps.

## 4 Package Information and Contact Assignments

### 4.1 289-Ball MAPBGA—Case 14 x 14 mm, 0.8 mm Pitch

The following notes apply to [Figure 44](#):

- All dimensions are in millimeters.
- Dimensioning and tolerancing per ASME Y14.5M-1994.
- Maximum solder bump diameter measured parallel to datum A.
- Datum A, the seating plane, is determined by the spherical crowns of the solder bumps.
- Parallelism measurement excludes any effect of mark on top surface of package.

Figure 44 shows the i.MX28 production package.

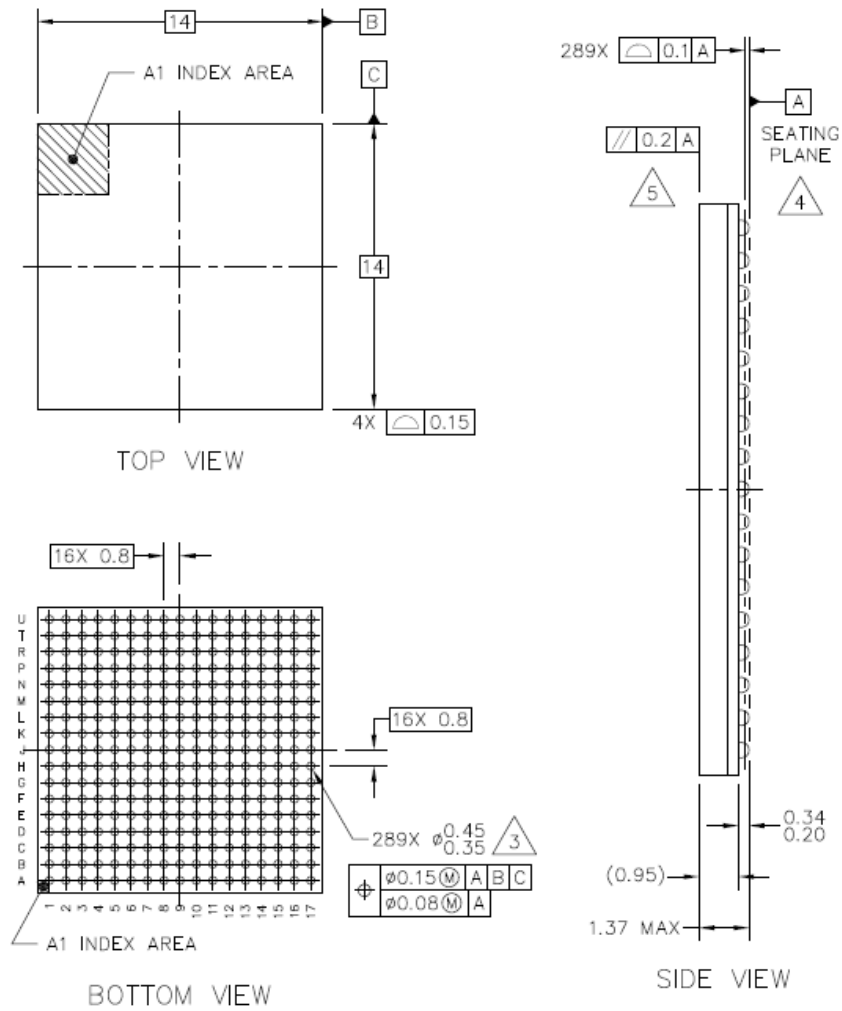


Figure 44. i.MX28 Production Package

## 4.2 Ground, Power, Sense, and Reference Contact Assignments

Table 65 shows power and ground contact assignments for the MAPBGA package.

Table 65. MAPBGA Power and Ground Contact Assignments

Contact Name	Contact Assignment
VDDA1	C13
VDDD	G12,G11,F10,F11,K12,F12,G10
VDDIO18	G8,F9,F8,G9
VDDIO33	H8,J8,N3,G3,E6,J9,J10,A7,E16
VDDIO33_EMI	N17
VDDIO_EMI	P11,R13,N13,N15,G17,M12,M10,G13,M11,L13,G15

**Table 65. MAPBGA Power and Ground Contact Assignments (continued)**

Contact Name	Contact Assignment
VDDIO_EMIQ	K15,J13,R15
VDDXTAL	C12
VSS	E15,L11,A1,K10,K11,J11,M14,H11,U1,H9,H12,H3,K9,C16,L10,H16,J12,H10,B7,E5,J15,A9,N4
VSSA1	B13
VSSA2	B11
VSSIO_EMI	F16,R10,H14,M16,F14,L12,P16,U17,T14,P14,R12

### 4.3 Signal Contact Assignments

Table 66 lists the i.MX287 MAPBGA package signal contact assignments.

**Table 66. MAPBGA Contact Assignments**

Signal Name	Contact Assignment	Signal Name	Contact Assignment	Signal Name	Contact Assignment
AUART0_CTS	J6	EMI_DQS1N	J16	LCD_D17	R3
AUART0_RTS	J7	EMI_ODT0	R17	LCD_D18	U4
AUART0_RX	G5	EMI_ODT1	T17	LCD_D19	T4
AUART0_TX	H5	EMI_RASN	R16	LCD_D20	R4
AUART1_CTS	K5	EMI_VREF0	R14	LCD_D21	U5
AUART1_RTS	J5	EMI_VREF1	K13	LCD_D22	T5
AUART1_RX	L4	EMI_WEN	T15	LCD_D23	R5
AUART1_TX	K4	ENET0_COL	J4	LCD_DOTCLK	N1
AUART2_CTS	H6	ENET0_CRS	J3	LCD_ENABLE	N5
AUART2_RTS	H7	ENET0_MDC	G4	LCD_HSYNC	M1
AUART2_RX	F6	ENET0_MDIO	H4	LCD_RD_E	P4
AUART2_TX	F5	ENET0_RXD0	H1	LCD_RESET	M6
AUART3_CTS	L6	ENET0_RXD1	H2	LCD_RS	M4
AUART3_RTS	K6	ENET0_RXD2	J1	LCD_VSYNC	L1
AUART3_RX	M5	ENET0_RXD3	J2	LCD_WR_RWN	K1
AUART3_TX	L5	ENET0_RX_CLK	F3	LRADC0	C15
BATTERY	A15	ENET0_RX_EN	E4	LRADC1	C9
DCDC_BATT	B15	ENET0_TXD0	F1	LRADC2	C8
DCDC_GND	A17	ENET0_TXD1	F2	LRADC3	D9
DCDC_LN1	B17	ENET0_TXD2	G1	LRADC4	D13
DCDC_LP	A16	ENET0_TXD3	G2	LRADC5	D15

**Table 66. MAPBGA Contact Assignments (continued)**

Signal Name	Contact Assignment	Signal Name	Contact Assignment	Signal Name	Contact Assignment
DCDC_VDDA	B16	ENET0_TX_CLK	E3	LRADC6	C14
DCDC_VDDD	D17	ENET0_TX_EN	F4	PSWITCH	A11
DCDC_VDDIO	C17	ENET_CLK	E2	PWM0	K7
DEBUG	B9	GPMI_ALE	P6	PWM1	L7
EMI_A00	U15	GPMI_CE0N	N7	PWM2	K8
EMI_A01	U12	GPMI_CE1N	N9	PWM3	E9
EMI_A02	U14	GPMI_CE2N	M7	PWM4	E10
EMI_A03	T11	GPMI_CE3N	M9	RESETN	A14
EMI_A04	U10	GPMI_CLE	P7	RTC_XTALI	D11
EMI_A05	R11	GPMI_D00	U8	RTC_XTALO	C11
EMI_A06	R9	GPMI_D01	T8	SAIF0_BITCLK	F7
EMI_A07	N11	GPMI_D02	R8	SAIF0_LRCLK	G6
EMI_A08	U9	GPMI_D03	U7	SAIF0_MCLK	G7
EMI_A09	P10	GPMI_D04	T7	SAIF0_SDATA0	E7
EMI_A10	U13	GPMI_D05	R7	SAIF1_SDATA0	E8
EMI_A11	T10	GPMI_D06	U6	SPDIF	D7
EMI_A12	U11	GPMI_D07	T6	SSP0_CMD	A4
EMI_A13	T9	GPMI_RDN	R6	SSP0_DATA0	B6
EMI_A14	N10	GPMI_RDY0	N6	SSP0_DATA1	C6
EMI_BA0	T16	GPMI_RDY1	N8	SSP0_DATA2	D6
EMI_BA1	T12	GPMI_RDY2	M8	SSP0_DATA3	A5
EMI_BA2	N12	GPMI_RDY3	L8	SSP0_DATA4	B5
EMI_CASN	U16	GPMI_RESETN	L9	SSP0_DATA5	C5
EMI_CE0N	P12	GPMI_WRN	P8	SSP0_DATA6	D5
EMI_CE1N	P9	HSADC0	B14	SSP0_DATA7	B4
EMI_CKE	T13	I2C0_SCL	C7	SSP0_DETECT	D10
EMI_CLK	L17	I2C0_SDA	D8	SSP0_SCK	A6
EMI_CLKN	L16	JTAG_RTCK	E14	SSP1_CMD	C1
EMI_D00	N16	JTAG_TCK	E11	SSP1_DATA0	D1
EMI_D01	M13	JTAG_TDI	E12	SSP1_DATA3	E1
EMI_D02	P15	JTAG_TDO	E13	SSP1_SCK	B1
EMI_D03	N14	JTAG_TMS	D12	SSP2_MISO	B3

**Table 66. MAPBGA Contact Assignments (continued)**

Signal Name	Contact Assignment
EMI_D04	P13
EMI_D05	P17
EMI_D06	L14
EMI_D07	M17
EMI_D08	G16
EMI_D09	H15
EMI_D10	G14
EMI_D11	J14
EMI_D12	H13
EMI_D13	H17
EMI_D14	F13
EMI_D15	F17
EMI_DDR_OPE N	K14
EMI_DDR_OPE N_FB	L15
EMI_DQM0	M15
EMI_DQM1	F15
EMI_DQS0	K17
EMI_DQS0N	K16
EMI_DQS1	J17

Signal Name	Contact Assignment
JTAG_TRST	D14
LCD_CS	P5
LCD_D00	K2
LCD_D01	K3
LCD_D02	L2
LCD_D03	L3
LCD_D04	M2
LCD_D05	M3
LCD_D06	N2
LCD_D07	P1
LCD_D08	P2
LCD_D09	P3
LCD_D10	R1
LCD_D11	R2
LCD_D12	T1
LCD_D13	T2
LCD_D14	U2
LCD_D15	U3
LCD_D16	T3

Signal Name	Contact Assignment
SSP2_MOSI	C3
SSP2_SCK	A3
SSP2_SS0	C4
SSP2_SS1	D3
SSP2_SS2	D4
SSP3_MISO	B2
SSP3_MOSI	C2
SSP3_SCK	A2
SSP3_SS0	D2
TESTMODE	C10
USB0DM	A10
USB0DP	B10
USB1DM	B8
USB1DP	A8
VDD1P5	D16
VDD4P2	A13
VDD5V	E17
XTALI	A12
XTALO	B12



## 4.4 i.MX287 Ball Map

Figure 45 shows the i.MX287 MAPBGA Ball Map.

	1	2	3	4	5	6	7	8	9	10	11	12	13	14	15	16	17	
A	VSS	SSP3_SCK	SSP2_SCK	SSP0_CMD	SSP0_DAT_A3	SSP0_SCK	VDDI_O33	USB1_DP	VSS	USB0_DM	PSWI_TCH	XTALI	VDD4_P2	RESE_TN	BATTERY	DCDC_LP	DCDC_GND	A
B	SSP1_SCK	SSP3_MISO	SSP2_MISO	SSP0_DAT_A7	SSP0_DAT_A4	SSP0_DAT_A0	VSS	USB1_DM	DEBU_G	USB0_DP	VSSA_2	XTALO	VSSA_1	HSAD_C0	DCDC_BAT	DCDC_VDD_A	DCDC_LN1	B
C	SSP1_CMD	SSP3_MOSI	SSP2_MOSI	SSP2_SS0	SSP0_DAT_A5	SSP0_DAT_A1	I2C0_SCL	LRAD_C2	LRAD_C1	TEST_MODE	RTC_XTALO	VDDX_TAL	VDDA_1	LRAD_C6	LRAD_C0	VSS	DCDC_VDD_IO	C
D	SSP1_DAT_A0	SSP3_SS0	SSP2_SS1	SSP2_SS2	SSP0_DAT_A6	SSP0_DAT_A2	SPDI_F	I2C0_SDA	LRAD_C3	SSP0_DETECT	RTC_XTALI	JTAG_TMS	LRAD_C4	JTAG_TRST	LRAD_C5	VDD1_P5	DCDC_VDD_D	D
E	SSP1_DAT_A3	ENET0_CLK	ENET0_TX_CLK	ENET0_RX_EN	VSS	VDDI_O33	SAIF0_SDA_TA0	SAIF1_SDA_TA0	PWM_3	PWM_4	JTAG_TCK	JTAG_TDI	JTAG_TDO	JTAG_RTC_K	VSS	VDDI_O33	VDD5_V	E
F	ENET0_TX_D0	ENET0_TX_D1	ENET0_RX_CLK	ENET0_TX_EN	AUAR_T2_TX	AUAR_T2_RX	SAIF0_BITLK	VDDI_O18	VDDI_O18	VDDD	VDDD	VDDD	EMI_D14	VSSI_OEM_I	EMI_DQM1	VSSI_OEM_I	EMI_D15	F
G	ENET0_TX_D2	ENET0_TX_D3	VDDI_O33	ENET0_MD_C	AUAR_T0_RX	SAIF0_LRC_LK	SAIF0_MCLK	VDDI_O18	VDDI_O18	VDDD	VDDD	VDDD	VDDI_OEM_I	EMI_D10	VDDI_OEM_I	EMI_D08	VDDI_OEM_I	G
H	ENET0_RX_D0	ENET0_RX_D1	VSS	ENET0_MD_IO	AUAR_T0_TX	AUAR_T2_CTS	AUAR_T2_RTS	VDDI_O33	VSS	VSS	VSS	VSS	EMI_D12	VSSI_OEM_I	EMI_D09	VSS	EMI_D13	H
J	ENET0_RX_D2	ENET0_RX_D3	ENET0_CR_S	ENET0_CO_L	AUAR_T1_RTS	AUAR_T0_CTS	AUAR_T0_RTS	VDDI_O33	VDDI_O33	VDDI_O33	VSS	VSS	VDDI_OEM_IQ	EMI_D11	VSS	EMI_DQS1_N	EMI_DQS1	J
K	LCD_WR_RWN	LCD_D00	LCD_D01	AUAR_T1_TX	AUAR_T1_CTS	AUAR_T3_RTS	PWM_0	PWM_2	VSS	VSS	VSS	VDDD	EMI_VREF1	EMI_DDR_OPEN	VDDI_OEM_IQ	EMI_DQS0_N	EMI_DQS0	K
L	LCD_VSYNC	LCD_D02	LCD_D03	AUAR_T1_RX	AUAR_T3_TX	AUAR_T3_CTS	PWM_1	GPMI_RDY_3	GPMI_RES_ETN	VSS	VSS	VSSI_OEM_I	VDDI_OEM_I	EMI_D06	EMI_DDR_OPEN_FB	EMI_CLKN	EMI_CLK	L
M	LCD_HSYNC	LCD_D04	LCD_D05	LCD_RS	AUAR_T3_RX	LCD_RESET	GPMI_CE2_N	GPMI_RDY_2	GPMI_CE3_N	VDDI_OEM_I	VDDI_OEM_I	VDDI_OEM_I	EMI_D01	VSS	EMI_DQM0	VSSI_OEM_I	EMI_D07	M
N	LCD_DOTCLK	LCD_D06	VDDI_O33	VSS	LCD_ENABLE	GPMI_RDY_0	GPMI_CE0_N	GPMI_RDY_1	GPMI_CE1_N	EMI_A14	EMI_A07	EMI_BA2	VDDI_OEM_I	EMI_D03	VDDI_OEM_I	EMI_D00	VDDI_O33_EMI	N
P	LCD_D07	LCD_D08	LCD_D09	LCD_RD_E	LCD_CS	GPMI_ALE	GPMI_CLE	GPMI_WR_N	EMI_CE1N	EMI_A09	VDDI_OEM_I	EMI_CE0N	EMI_D04	VSSI_OEM_I	EMI_D02	VSSI_OEM_I	EMI_D05	P
R	LCD_D10	LCD_D11	LCD_D17	LCD_D20	LCD_D23	GPMI_RDN	GPMI_D05	GPMI_D02	EMI_A06	VSSI_OEM_I	EMI_A05	VSSI_OEM_I	VDDI_OEM_I	EMI_VREF0	VDDI_OEM_IQ	EMI_RASN	EMI_ODT0	R
T	LCD_D12	LCD_D13	LCD_D16	LCD_D19	LCD_D22	GPMI_D07	GPMI_D04	GPMI_D01	EMI_A13	EMI_A11	EMI_A03	EMI_BA1	EMI_CKE	VSSI_OEM_I	EMI_WEN	EMI_BA0	EMI_ODT1	T
U	VSS	LCD_D14	LCD_D15	LCD_D18	LCD_D21	GPMI_D06	GPMI_D03	GPMI_D00	EMI_A08	EMI_A04	EMI_A12	EMI_A01	EMI_A10	EMI_A02	EMI_A00	EMI_CASN	VSSI_OEM_I	U

Figure 45. 289-pin i.MX287 MAPBGA Ball Map

## 4.5 i.MX286 Ball Map

Figure 46 shows the i.MX286 MAPBGA ball map.

	1	2	3	4	5	6	7	8	9	10	11	12	13	14	15	16	17	
A	VSS	NC	SSP2_SCK	SSP0_CMD	SSP0_DAT_A3	SSP0_SCK	VDDI_O33	USB1_DP	VSS	USB0_DM	PSWI_TCH	XTALI	VDD4_P2	RESE_TN	BATTERY	DCDC_LP	DCDC_GND	A
B	NC	NC	SSP2_MIS_O	SSP0_DAT_A7	SSP0_DAT_A4	SSP0_DAT_A0	VSS	USB1_DM	DEBU_G	USB0_DP	VSSA_2	XTALO	VSSA_1	HSAD_C0	DCDC_BAT	DCDC_VDD_A	DCDC_LN1	B
C	NC	NC	SSP2_MOS_I	SSP2_SS0	SSP0_DAT_A5	SSP0_DAT_A1	I2C0_SCL	LRAD_C2	LRAD_C1	TEST_MODE	RTC_XTALO	VDDX_TAL	VDDA_1	LRAD_C6	LRAD_C0	VSS	DCDC_VDD_IO	C
D	NC	NC	SSP2_SS1	SSP2_SS2	SSP0_DAT_A6	SSP0_DAT_A2	SPDI_F	I2C0_SDA	LRAD_C3	SSP0_DETECT	RTC_XTALI	JTAG_TMS	LRAD_C4	JTAG_TRST	LRAD_C5	VDD1_P5	DCDC_VDD_D	D
E	NC	ENET_CLK	NC	ENET0_RX_EN	VSS	VDDI_O33	SAIF0_SDA_TA0	SAIF1_SDA_TA0	PWM_3	PWM_4	JTAG_TCK	JTAG_TDI	JTAG_TDO	JTAG_RTC_K	VSS	VDDI_O33	VDD5_V	E
F	ENET0_TX_D0	ENET0_TX_D1	NC	ENET0_TX_EN	NC	NC	SAIF0_BITCLK	VDDI_O18	VDDI_O18	VDDD	VDDD	VDDD	EMI_D14	VSSI_OEM_I	EMI_DQM1	VSSI_OEM_I	EMI_D15	F
G	NC	NC	VDDI_O33	ENET0_MD_C	AUAR_TO_RX	SAIF0_LRC_LK	SAIF0_MCLK	VDDI_O18	VDDI_O18	VDDD	VDDD	VDDD	VDDI_OEM_I	EMI_D10	VDDI_OEM_I	EMI_D08	VDDI_OEM_I	G
H	ENET0_RX_D0	ENET0_RX_D1	VSS	ENET0_MD_IO	AUAR_TO_TX	NC	NC	VDDI_O33	VSS	VSS	VSS	VSS	EMI_D12	VSSI_OEM_I	EMI_D09	VSS	EMI_D13	H
J	NC	NC	NC	NC	NC	AUAR_TO_CTS	AUAR_TO_RS	VDDI_O33	VDDI_O33	VDDI_O33	VSS	VSS	VDDI_OEM_IQ	EMI_D11	VSS	EMI_DQS1_N	EMI_DQS1	J
K	LCD_WR_RWN	LCD_D00	LCD_D01	AUAR_T1_TX	NC	NC	PWM_0	PWM_2	VSS	VSS	VSS	VDDD	EMI_VREF1	EMI_DDR_OPEN	VDDI_OEM_IQ	EMI_DQS0_N	EMI_DQS0	K
L	NC	LCD_D02	LCD_D03	AUAR_T1_RX	NC	NC	PWM_1	GPMI_RDY_3	GPMI_RES_ETN	VSS	VSS	VSSI_OEM_I	VDDI_OEM_I	EMI_D06	EMI_DDR_OPEN_FB	EMI_CLKN	EMI_CLK	L
M	NC	LCD_D04	LCD_D05	LCD_RS	NC	LCD_RESET	GPMI_CE2_N	GPMI_RDY_2	GPMI_CE3_N	VDDI_OEM_I	VDDI_OEM_I	VDDI_OEM_I	EMI_D01	VSS	EMI_DQM0	VSSI_OEM_I	EMI_D07	M
N	NC	LCD_D06	VDDI_O33	VSS	NC	GPMI_RDY_0	GPMI_CE0_N	GPMI_RDY_1	GPMI_CE1_N	EMI_A14	EMI_A07	EMI_BA2	VDDI_OEM_I	EMI_D03	VDDI_OEM_I	EMI_D00	VDDI_O33_EMI	N
P	LCD_D07	LCD_D08	LCD_D09	LCD_RD_E	LCD_CS	GPMI_ALE	GPMI_CLE	GPMI_WR_N	EMI_CE1N	EMI_A09	VDDI_OEM_I	EMI_CE0N	EMI_D04	VSSI_OEM_I	EMI_D02	VSSI_OEM_I	EMI_D05	P
R	LCD_D10	LCD_D11	LCD_D17	LCD_D20	LCD_D23	GPMI_RDN	GPMI_D05	GPMI_D02	EMI_A06	VSSI_OEM_I	EMI_A05	VSSI_OEM_I	VDDI_OEM_I	EMI_VREF0	VDDI_OEM_IQ	EMI_RASN	EMI_ODT0	R
T	LCD_D12	LCD_D13	LCD_D16	LCD_D19	LCD_D22	GPMI_D07	GPMI_D04	GPMI_D01	EMI_A13	EMI_A11	EMI_A03	EMI_BA1	EMI_CKE	VSSI_OEM_I	EMI_WEN	EMI_BA0	EMI_ODT1	T
U	VSS	LCD_D14	LCD_D15	LCD_D18	LCD_D21	GPMI_D06	GPMI_D03	GPMI_D00	EMI_A08	EMI_A04	EMI_A12	EMI_A01	EMI_A10	EMI_A02	EMI_A00	EMI_CASN	VSSI_OEM_I	U
	1	2	3	4	5	6	7	8	9	10	11	12	13	14	15	16	17	

Figure 46. 289-pin i.MX286 MAPBGA Ball Map

## 4.6 i.MX283 Ball Map

Figure 47 shows the i.MX283 MAPBGA ball map.

	1	2	3	4	5	6	7	8	9	10	11	12	13	14	15	16	17	
A	VSS	NC	SSP2_S CK	SSP0_C MD	SSP0_D ATA3	SSP0_S CK	VDDIO3 3	USB1DP	VSS	USB0D M	PSWITC H	XTALI	VDD4P2	RESETN	BATTER Y	DCDC_L P	DCDC_ GND	A
B	NC	NC	SSP2_M ISO	SSP0_D ATA7	SSP0_D ATA4	SSP0_D ATA0	VSS	USB1D M	DEBUG	USB0DP	VSSA2	XTALO	VSSA1	HSADC0	DCDC_B ATT	DCDC_V DDA	DCDC_L N1	B
C	NC	NC	SSP2_M OSI	SSP2_S S0	SSP0_D ATA5	SSP0_D ATA1	I2C0_SC L	LRADC2	LRADC1	TESTM ODE	RTC_XT ALO	VDDXT AL	VDDA1	LRADC6	LRADC0	VSS	DCDC_V DDIO	C
D	NC	NC	SSP2_S S1	SSP2_S S2	SSP0_D ATA6	SSP0_D ATA2	NC	I2C0_SD A	LRADC3	SSP0_D ETECT	RTC_XT ALI	JTAG_T MS	LRADC4	JTAG_T RST	LRADC5	VDD1P5	DCDC_V DDD	D
E	NC	ENET_C LK	NC	ENET0_ RX_EN	VSS	VDDIO3 3	SAIF0_S DATA0	SAIF1_S DATA0	PWM3	PWM4	JTAG_T CK	JTAG_T DI	JTAG_T DO	JTAG_R TCK	VSS	VDDIO3 3	VDD5V	E
F	ENET0_ TXD0	ENET0_ TXD1	NC	ENET0_ TX_EN	NC	NC	SAIF0_B ITCLK	VDDIO1 8	VDDIO1 8	VDDD	VDDD	VDDD	EMI_D1 4	VSSIO_ EMI	EMI_D QM1	VSSIO_ EMI	EMI_D1 5	F
G	NC	NC	VDDIO3 3	ENET0_ MDC	AUART 0_RX	SAIF0_L RCLK	SAIF0_ MCLK	VDDIO1 8	VDDIO1 8	VDDD	VDDD	VDDD	VDDIO_ EMI	EMI_D1 0	VDDIO_ EMI	EMI_D0 8	VDDIO_ EMI	G
H	ENET0_ RXD0	ENET0_ RXD1	VSS	ENET0_ MDIO	AUART 0_TX	NC	NC	VDDIO3 3	VSS	VSS	VSS	VSS	EMI_D1 2	VSSIO_ EMI	EMI_D0 9	VSS	EMI_D1 3	H
J	NC	NC	NC	NC	NC	AUART 0_CTS	AUART 0_RTS	VDDIO3 3	VDDIO3 3	VDDIO3 3	VSS	VSS	VDDIO_ EMIQ	EMI_D1 1	VSS	EMI_D QS1N	EMI_D QS1	J
K	LCD_W R_RWN	LCD_D0 0	LCD_D0 1	AUART 1_TX	NC	NC	PWM0	PWM2	VSS	VSS	VSS	VDDD	EMI_VR EF1	EMI_DD R_OPE	VDDIO_ EMIQ	EMI_D QS0N	EMI_D QS0	K
L	NC	LCD_D0 2	LCD_D0 3	AUART 1_RX	NC	NC	PWM1	NC	GPMI_R ESETN	VSS	VSS	VSSIO_ EMI	VDDIO_ EMI	EMI_D0 6	EMI_DD R_OPE	EMI_CL KN	EMI_CL K	L
M	NC	LCD_D0 4	LCD_D0 5	LCD_RS	NC	LCD_RE SET	NC	NC	NC	VDDIO_ EMI	VDDIO_ EMI	VDDIO_ EMI	EMI_D0 1	VSS	EMI_D QM0	VSSIO_ EMI	EMI_D0 7	M
N	NC	LCD_D0 6	VDDIO3 3	VSS	NC	GPMI_R DY0	GPMI_C E0N	GPMI_R DY1	GPMI_C E1N	EMI_A1 4	EMI_A0 7	EMI_BA 2	VDDIO_ EMI	EMI_D0 3	EMI	EMI_D0 0	VDDIO3 3_EMI	N
P	LCD_D0 7	LCD_D0 8	LCD_D0 9	LCD_RD _E	LCD_CS	GPMI_A LE	GPMI_C LE	GPMI_ WRN	EMI_CE 1N	EMI_A0 9	VDDIO_ EMI	EMI_CE 0N	EMI_D0 4	VSSIO_ EMI	EMI_D0 2	VSSIO_ EMI	EMI_D0 5	P
R	LCD_D1 0	LCD_D1 1	LCD_D1 7	LCD_D2 0	LCD_D2 3	GPMI_R DN	GPMI_ D05	GPMI_ D02	EMI_A0 6	VSSIO_ EMI	EMI_A0 5	VSSIO_ EMI	VDDIO_ EMI	EMI_VR EF0	VDDIO_ EMIQ	EMI_RA SN	EMI_O DT0	R
T	LCD_D1 2	LCD_D1 3	LCD_D1 6	LCD_D1 9	LCD_D2 2	GPMI_ D07	GPMI_ D04	GPMI_ D01	EMI_A1 3	EMI_A1 1	EMI_A0 3	EMI_BA 1	EMI_CK E	VSSIO_ EMI	EMI_W EN	EMI_BA 0	EMI_O DT1	T
U	VSS	LCD_D1 4	LCD_D1 5	LCD_D1 8	LCD_D2 1	GPMI_ D06	GPMI_ D03	GPMI_ D00	EMI_A0 8	EMI_A0 4	EMI_A1 2	EMI_A0 1	EMI_A1 0	EMI_A0 2	EMI_A0 0	EMI_CA SN	VSSIO_ EMI	U
	1	2	3	4	5	6	7	8	9	10	11	12	13	14	15	16	17	

Figure 47. 289-pin i.MX283 MAPBGA Ball Map

## 4.7 i.MX280 Ball Map

Figure 48 shows the i.MX280 MAPBGA ball map.

	1	2	3	4	5	6	7	8	9	10	11	12	13	14	15	16	17	
A	VSS	NC	SSP2_SCK	SSP0_CMD	SSP0_DATA3	SSP0_SCK	VDDIO3_3	USB1D_P	VSS	USB0D_M	PSWITCH	XTALI	VDD4P_2	RESETN	BATTERY	DCDC_LP	DCDC_GND	A
B	NC	NC	SSP2_MISO	SSP0_DATA7	SSP0_DATA4	SSP0_DATA0	VSS	USB1D_M	DEBUG	USB0D_P	VSSA2	XTALO	VSSA1	HSADC_0	DCDC_BATT	DCDC_VDDA	DCDC_N1	B
C	NC	NC	SSP2_MOSI	SSP2_S0	SSP0_DATA5	SSP0_DATA1	I2C0_SCL	LRADC2	LRADC1	TESTMODE	RTC_XTALO	VDDXTAL	VDDA1	LRADC6	LRADC0	VSS	DCDC_VDDIO	C
D	NC	NC	SSP2_S1	SSP2_S2	SSP0_DATA6	SSP0_DATA2	NC	I2C0_SDA	LRADC3	SSP0_DETECT	RTC_XTALI	JTAG_TMS	LRADC4	JTAG_RST	LRADC5	VDD1P_5	DCDC_VDDD	D
E	NC	ENET_CLK	NC	ENET0_RX_EN	VSS	VDDIO3_3	SAIF0_DATA0	SAIF1_DATA0	PWM3	PWM4	JTAG_TCK	JTAG_DI	JTAG_DO	JTAG_TCK	VSS	VDDIO3_3	VDD5V	E
F	ENET0_TXD0	ENET0_TXD1	NC	ENET0_TX_EN	NC	NC	SAIF0_BITCLK	VDDIO1_8	VDDIO1_8	VDDD	VDDD	VDDD	EMI_D1_4	VSSIO_EMI	EMI_QM1	VSSIO_EMI	EMI_D1_5	F
G	NC	NC	VDDIO3_3	ENET0_MDC	AUART_0_RX	SAIF0_RCLK	SAIF0_MCLK	VDDIO1_8	VDDIO1_8	VDDD	VDDD	VDDD	VDDIO_EMI	EMI_D1_0	VDDIO_EMI	EMI_D0_8	VDDIO_EMI	G
H	ENET0_RXD0	ENET0_RXD1	VSS	ENET0_MDIO	AUART_0_TX	NC	NC	VDDIO3_3	VSS	VSS	VSS	VSS	EMI_D1_2	VSSIO_EMI	EMI_D0_9	VSS	EMI_D1_3	H
J	NC	NC	NC	NC	NC	AUART_0_CTS	AUART_0_RTS	VDDIO3_3	VDDIO3_3	VDDIO3_3	VSS	VSS	VDDIO_EMI	EMI_D1_1	VSS	EMI_D_QS1N	EMI_D_QS1	J
K	ETM_TCLK	ETM_DA0	ETM_DA1	AUART_1_TX	NC	NC	PWM0	PWM2	VSS	VSS	VSS	VDDD	EMI_VREF1	EMI_DR_OPEN	VDDIO_EMI	EMI_D_QS0N	EMI_D_QS0	K
L	NC	ETM_DA2	ETM_DA3	AUART_1_RX	NC	NC	PWM1	NC	GPMI_RESETN	VSS	VSS	VSSIO_EMI	VDDIO_EMI	EMI_D0_6	EMI_DR_OPEN_FB	EMI_CLKN	EMI_CLKK	L
M	NC	ETM_DA4	ETM_DA5	GPIO_B1P26	NC	NC	NC	NC	NC	VDDIO_EMI	VDDIO_EMI	VDDIO_EMI	EMI_D0_1	VSS	EMI_D_QM0	VSSIO_EMI	EMI_D0_7	M
N	NC	ETM_DA6	VDDIO3_3	VSS	NC	GPMI_RDY0	GPMI_CE0N	GPMI_RDY1	GPMI_CE1N	EMI_A1_4	EMI_A0_7	EMI_BA_2	VDDIO_EMI	EMI_D0_3	VDDIO_EMI	EMI_D0_0	VDDIO3_3_EMI	N
P	ETM_DA7	NC	NC	ETM_CTL	NC	GPMI_ALE	GPMI_CLE	GPMI_WRN	EMI_CE1N	EMI_A0_9	VDDIO_EMI	EMI_CE0N	EMI_D0_4	VSSIO_EMI	EMI_D0_2	VSSIO_EMI	EMI_D0_5	P
R	NC	NC	NC	NC	NC	GPMI_RDN	GPMI_D05	GPMI_D02	EMI_A0_6	VSSIO_EMI	EMI_A0_5	VSSIO_EMI	VDDIO_EMI	EMI_VREF0	VDDIO_EMI	EMI_RASN	EMI_ODT0	R
T	NC	NC	NC	NC	NC	GPMI_D07	GPMI_D04	GPMI_D01	EMI_A1_3	EMI_A1_1	EMI_A0_3	EMI_BA_1	EMI_CKE	VSSIO_EMI	EMI_WEN	EMI_BA_0	EMI_ODT1	T
U	VSS	NC	NC	NC	NC	GPMI_D06	GPMI_D03	GPMI_D00	EMI_A0_8	EMI_A0_4	EMI_A1_2	EMI_A0_1	EMI_A1_0	EMI_A0_2	EMI_A0_0	EMI_CASN	VSSIO_EMI	U

Figure 48. 289-pin i.MX280 MAPBGA Ball Map

## 5 Revision History

Table 67 summarizes revisions to this document.

**Table 67. Revision History**

Rev. #	Date	Revision
Rev. 1	04/2011	<ul style="list-style-type: none"> <li>• Updated <a href="#">Section 1.1</a>, "Device Features."</li> <li>• Added <a href="#">Section 3.2</a>, "Thermal Characteristics."</li> <li>• In <a href="#">Table 1</a>, "Ordering Information," on page 3, added two rows.</li> <li>• Updated <a href="#">Table 2</a>, "i.MX28 Functional Differences," on page 3.</li> <li>• Updated <a href="#">Table 4</a>, "i.MX28 Digital and Analog Modules," on page 6.</li> <li>• In <a href="#">Table 8</a>, "Recommended Power Supply Operating Conditions," on page 13, updated BATT row.</li> <li>• Updated <a href="#">Table 9</a>, "Operating Temperature Conditions," on page 13.</li> <li>• Replaced the term "DC Characteristics" with "Power Consumption" in the title and introduction of <a href="#">Table 12</a>, "Power Consumption," on page 14. Also changed Dissipation to Consumption in first row.</li> <li>• Updated <a href="#">Table 26</a>, "Digital Pin DC Characteristics for GPIO in 3.3-V Mode," on page 21.</li> <li>• Updated <a href="#">Table 27</a>, "Digital Pin DC Characteristics for GPIO in 1.8 V Mode," on page 23.</li> <li>• Updated and added a footnote to <a href="#">Table 34</a>, "Ethernet PLL Specifications," on page 30.</li> <li>• Updated DDR1 row of <a href="#">Table 35</a>, "EMI Command/Address AC Timing," on page 31.</li> <li>• In <a href="#">Section 4.6</a>, "i.MX283 Ball Map," replaced <a href="#">Figure 47</a>.</li> <li>• Added <a href="#">Section 4.7</a>, "i.MX280 Ball Map."</li> </ul>
Rev. 0	09/2010	Initial release.

## How to Reach Us:

### Home Page:

[www.freescale.com](http://www.freescale.com)

### Web Support:

<http://www.freescale.com/support>

### USA/Europe or Locations Not Listed:

Freescale Semiconductor, Inc.  
Technical Information Center, EL516  
2100 East Elliot Road  
Tempe, Arizona 85284  
1-800-521-6274 or  
+1-480-768-2130  
[www.freescale.com/support](http://www.freescale.com/support)

### Europe, Middle East, and Africa:

Freescale Halbleiter Deutschland GmbH  
Technical Information Center  
Schatzbogen 7  
81829 Muenchen, Germany  
+44 1296 380 456 (English)  
+46 8 52200080 (English)  
+49 89 92103 559 (German)  
+33 1 69 35 48 48 (French)  
[www.freescale.com/support](http://www.freescale.com/support)

### Japan:

Freescale Semiconductor Japan Ltd.  
Headquarters  
ARCO Tower 15F  
1-8-1, Shimo-Meguro, Meguro-ku  
Tokyo 153-0064  
Japan  
0120 191014 or  
+81 3 5437 9125  
[support.japan@freescale.com](mailto:support.japan@freescale.com)

### Asia/Pacific:

Freescale Semiconductor China Ltd.  
Exchange Building 23F  
No. 118 Jianguo Road  
Chaoyang District  
Beijing 100022  
China  
+86 10 5879 8000  
[support.asia@freescale.com](mailto:support.asia@freescale.com)

### For Literature Requests Only:

Freescale Semiconductor  
Literature Distribution Center  
1-800 441-2447 or  
+1-303-675-2140  
Fax: +1-303-675-2150  
[LDCForFreescaleSemiconductor@hibbertgroup.com](mailto:LDCForFreescaleSemiconductor@hibbertgroup.com)

Information in this document is provided solely to enable system and software implementers to use Freescale Semiconductor products. There are no express or implied copyright licenses granted hereunder to design or fabricate any integrated circuits or integrated circuits based on the information in this document.

Freescale Semiconductor reserves the right to make changes without further notice to any products herein. Freescale Semiconductor makes no warranty, representation or guarantee regarding the suitability of its products for any particular purpose, nor does Freescale Semiconductor assume any liability arising out of the application or use of any product or circuit, and specifically disclaims any and all liability, including without limitation consequential or incidental damages. "Typical" parameters that may be provided in Freescale Semiconductor data sheets and/or specifications can and do vary in different applications and actual performance may vary over time. All operating parameters, including "Typicals", must be validated for each customer application by customer's technical experts. Freescale Semiconductor does not convey any license under its patent rights nor the rights of others. Freescale Semiconductor products are not designed, intended, or authorized for use as components in systems intended for surgical implant into the body, or other applications intended to support or sustain life, or for any other application in which the failure of the Freescale Semiconductor product could create a situation where personal injury or death may occur. Should Buyer purchase or use Freescale Semiconductor products for any such unintended or unauthorized application, Buyer shall indemnify and hold Freescale Semiconductor and its officers, employees, subsidiaries, affiliates, and distributors harmless against all claims, costs, damages, and expenses, and reasonable attorney fees arising out of, directly or indirectly, any claim of personal injury or death associated with such unintended or unauthorized use, even if such claim alleges that Freescale Semiconductor was negligent regarding the design or manufacture of the part.

RoHS-compliant and/or Pb-free versions of Freescale products have the functionality and electrical characteristics as their non-RoHS-compliant and/or non-Pb-free counterparts. For further information, see <http://www.freescale.com> or contact your Freescale sales representative.

For information on Freescale's Environmental Products program, go to <http://www.freescale.com/epp>.

Freescale and the Freescale logo are trademarks of Freescale Semiconductor, Inc. All other product or service names are the property of their respective owners. ARM is the registered trademark of ARM Limited. ARM926EJ-S, CoreSight, and ETM9 are trademarks of ARM Limited. IEEE 1588 and IEEE 1149 are trademarks and IEEE 802.3 is a registered trademark of the Institute of Electrical and Electronics Engineers, Inc. (IEEE). This product is not endorsed or approved by the IEEE.

© Freescale Semiconductor, Inc., 2011. All rights reserved.

Document Number: IMX28CEC

Rev. 1  
04/2011

